

Anexos

Anexo I

**Información Catastral recopilada de la
municipalidad de Barranco, presentada a
nivel de lote y ordenada por sectores y
manzanas.**

Sector 1

Manzana 1

Lote	Tipo(s) de Usos	Año(s) de Contrucc.	Material	Estado	Muros	Techo	Pisos
1	Oficinas	1996	Adob,Lad	Reg-malo	E	G,H	2
2	Casa	1955,1995	Lad.	Reg.	D	D	2
3	Casa	1949	Lad.	Bueno	D	D	2
4	Casa	1949	Lad.	Bueno	C	D	2
5	Casa	1949	Lad.	Bueno	C	D	2
6	Casa	1958	C.A.	Bueno	B	D	2
9	Edificio	1993	Lad.	Bueno	C	D	3
10	Casa	1953	Lad.	Bueno	C	D	3
11	Casa	1954	Lad.	Bueno	C	D	3
12	Casa	1960	Lad.	Bueno	C	D	2
13	Estudio de Abog.	1959	Lad.	Bueno	C	D	2
14	Casas(3)	1948,1960,1948	Lad.	Bueno	C	D	3
15	Casa	1948	Lad.	Bueno	C	D	3
16	Casa	1952	Lad.	Bueno	C	D	2
17	Quinta	1947	Lad.	Bueno	C	D	1
18	Quinta	1949	Lad.	Bueno	D	D	2
19	Quinta	1965	Lad.	Bueno	C	D	2

Manzana 2

Lote	Tipo(s) de Usos	Año(s) de Contrucc.	Material	Estado	Muros	Techo	Pisos
1	Casa	1978	Lad.	Reg.	C	D	3
2	Casa	1967	Lad.	Bueno	C	D	3
3	Casa	1955	Lad.	Reg.	C	D	2
4	Quinta	1962-1967	Lad.	Reg-Bueno	C	D	3
6	Casa	1963	Lad.	Bueno	C	D	2
7	Casa	1963	Lad.	Bueno	C	D	3
8	Casas	1963,1991	Lad.	Bueno	C	D	3
9	Casa	1984	Lad.	Bueno	C	D	2
10	Casa	1971	C.A.	Reg.	B	D	2
13	Casa	1962	Lad.	Reg.	C	D	3
14	Estacionamiento	1973	Adob.	Malo	F	F	1

Manzana 3

Lote	Tipo(s) de Usos	Año(s) de Contrucc.	Material	Estado	Muros	Techo	Pisos
1	Of. Comercial	1965	Lad.	Bueno	C	D	3
2	Casa	1965	Lad.	Bueno	C	D	3
3	Casa	1965	Lad.	Bueno	C	D	3
4	Casa	1965	Lad.	Reg.	C	D	3
5	Casa	1957	Lad.	Bueno	C	D	3
6	Casa	1965	Lad.	Reg.	C	D	3
7	Casa	1980	Lad.	Bueno	C	D	3
8	Edificio de Viv.	1982	C.A.	Bueno	B	D	12
9	Casa	1965	Lad.	Reg.	C	D	2
10	Casa	1970	Lad.	Bueno	C	D	3
12	Casa	1963	Lad.	Bueno	C	D	2
13	Edificio	1980	C.A.	Bueno	B	D	3
14	Casa	1960	Lad.	Reg.	C	D	2
15	Casa	1980	Lad.	Reg.	C	D	2
16	Edificio	1948	Lad.	Bueno	C	D	2
17	Casas	1960	Lad.	Bueno	C	D	2
18	Casas	1956	Lad.	Reg.	C	D	2
19	Edificio	1947	Lad.	Reg.	C	D	3
20	Casas	1959	Lad.	Bueno	D	D	2
21	Casas	1961	Lad.	Bueno	C	D	3

Manzana 4

Lote	Tipo(s) de Usos	Año(s) de Contrucc.	Material	Estado	Muros	Techo	Pisos
1	Casa	1965	Lad.	Reg.	C	D	3
2	Casa	1954	Lad.	Reg.	C	D	2
3	Casa	1962	Lad.	Bueno	C	D	3
4	Casa	1965	Lad.	Bueno	C	D	3
5	Casa	1968	Lad.	Bueno	C	D	3
6	Casa	1956	Lad.	Bueno	C	D	2
7	Casa	1980	Lad.	Bueno	C	D	2
8	Casa	1967	Lad.	Bueno	C	D	3
9	Casa	1968	Lad.	Reg.	C	D	2
10	Casa	1964	Lad.	Bueno	C	D	3
11	Casa	1964	Lad.	Bueno	C	D	3
12	Casa	1964	Lad.	Reg.	C	D	2
13	Casa	1964	Lad.	Bueno	C	D	3
14	Casa	1964	Lad.	Reg.	C	D	2
15	Casa	1965	Lad.	Bueno	C	D	2
16	Casa	1964	Lad.	Reg.	C	D	3
17	Casa	1964	Lad.	Reg.	C	D	2
18	Casa	1964	Lad.	Bueno	C	D	3
19	Casa	1964	Lad.	Bueno	C	D	3
20	Casa	1964	Lad.	Bueno	C	D	3
21	Casa	1964	Lad.	Reg.	C	D	2
22	Casa	1964	Lad.	Bueno	C	D	2
23	Casa	1968	Lad.	Bueno	C	D	3
24	Casa	1954	Lad.	Bueno	C	D	2
25	Casa	1967	Lad.	Reg.	C	D	3
26	Casa	1965	Lad.	Bueno	C	D	2
27	Casa	1964	Lad.	Reg.	C	D	3
28	Casa	1965	Lad.	Bueno	C	D	2
29	Casa	1965	Lad.	Bueno	C	D	3
30	Casa	1965	Lad.	Reg.	C	D	3

Manzana 8

Lote	Tipo(s) de Usos	Año(s) de Contrucc.	Material	Estado	Muros	Techo	Pisos
2	Casa	1945	Adob.	Reg.	F	H	1
3	Casa	1964	Lad.	Reg.	C	D	2
5	Quinta	1949	Adob.	Mal-Reg.	F	H-F	1
6	Colegio	1924, 1985, 1970	Adob, Lad, C.A.	Reg, Bueno	F, C, B	F, D, D	1, 3, 4
9	Casa	1944, 1995	Adob, C.A.	Reg, Bueno	F, B	F, D	1, 4
10	Casa	1962, 1928	Lad.	Reg.	C, D	D, G	2
12	Casas	1927-1999	Adob.	Reg.	F	G-F	2
13	Casas	1959	Adob.	Malo	F	F	1
14	Casas	1968	Lad.	Bueno	C	D	2

Manzana 11

Lote	Tipo(s) de Usos	Año(s) de Contrucc.	Material	Estado	Muros	Techo	Pisos
1	Casa	1968	Lad.	Reg.	C	D	1
2	Casa	1964	Lad.	Bueno	C	D	3
3	Casa	1967	Lad.	Bueno	C	D	3
4	Casa	1982	Lad.	Bueno	C	D	3
5	Casa	1968	Lad.	Reg.	C	D	3
7	Casa	1968, 1994	Lad.	Bueno	C	D	3, 2
8	Casa	1999	C.A	Bueno	B	C	2
12	Desocupado	1949	Lad.	Malo	D	D	2
13	Depósito	1997	C.A	Bueno	B	C	3
14	Imprenta	1960	Lad.	Bueno	C	D	2
15	Casa	1971	C.A	Bueno	B	D	3
16	Edificio	1982	C.A	Bueno	B	D	4
18	Casas	1974	Lad.	Bueno	C	D	3

Manzana 13

Lote	Tipo(s) de Usos	Año(s) de Construcc.	Material	Estado	Muros	Techo	Pisos
1	Casa	1950	Lad.	Bueno	C	F	1
2	Edificio Viv.	1989	Lad.	Muy Bueno	C	D	4
3	Casa	1923,1994	Adob-Lad.	Reg-Bueno	F-D	F-G	1
4	Casa	1983-1993	Lad.	Bueno	C	D	3
5	Serv. Técnicos	1965-1996	Lad.	Bueno	C	D	3
6	Casa	1947	Lad.	Bueno	C	D	3
7	Casa	1949	Lad.	Bueno	C	D	3
8	Casa	1949	Lad.	Bueno	C	D	3
9	Casa	1938	Lad.	Reg.	D	F	1
10	Casa	1935	Lad.	Reg.	D	D	1
12	Casa	1938	Lad.	Bueno	D	F	1
13	Casa	1935	Lad.	Reg.	D	F	1
14	Casa	1938	Lad.	Reg.	D	F	1
15	Casa	1938	Lad.	Reg.	D	F	1
16	Casa	1939	Lad.	Buen,Reg.	C	D	3

Manzana 15

Lote	Tipo(s) de Usos	Año(s) de Construcc.	Material	Estado	Muros	Techo	Pisos
1	Casa	1930	Adob.	Reg.	F	F	1
2	Casa	1943	Lad.	Reg.	D	H	1
3	Casa	1986	Lad.	Bueno	C	D	3
4	Casa	1952	Lad.	Bueno	C	D	3
5	Casa	1952	Lad.	Bueno	C	D	1
6	Edificio	1996	C.A	Muy Bueno	B	D	5
7	Casa	1992	Lad.	Reg.	C	D	3
8	Hostal	1996	C.A	Muy Bueno	B	D	6
9	Casas	1942	Lad.	Reg.	C	D	2
10	Quinta	1944-1948	Lad.	Buen-Reg.	C	D	2-3
11	Casa	1989	Lad.	Bueno	C	D	3
12	Casa	1940	Adob.	Reg.	F	H	1
13	Casa	1932	Lad.	Reg.	C	D	2
14	Casa	1931	Adob.	Reg.	F	F	1

Manzana 16

Lote	Tipo(s) de Usos	Año(s) de Construcc.	Material	Estado	Muros	Techo	Pisos
1	Coliseo	1995	Lad.	Bueno	C	D	1

Manzana 18

Lote	Tipo(s) de Usos	Año(s) de Construcc.	Material	Estado	Muros	Techo	Pisos
1	Grifo	1965	Lad.	Reg.	C	D	1

Manzana 19

Lote	Tipo(s) de Usos	Año(s) de Construcc.	Material	Estado	Muros	Techo	Pisos
2	Edificio de Viv.	1997	C.A.	Muy Bueno	B	D	8
3	Casa	1960	Lad.	Bueno	C	D	2
4	Edificio de Viv.	1960	Lad.	Bueno	C	D	1
6	Casa	1960	Lad.	Reg.	C	D	2
7	Casa	1960	Lad.	Reg.	C	D	2
8	Casas	1956	Lad.	Bueno	C	D	3
10	Taller	1948	Lad.	Bueno	D	D	2
11	Quinta	1951	Lad.	Reg.	C	D	1
12	Edificio	1962	Lad.	Bueno	C	D	3
13	Casa	1960	Lad.	Bueno	C	D	3
14	Casa	1960	Lad.	Reg.	C	D	3
16	Casas	1961,1986	Lad.	Bueno	C	D	2
18	Edificio	1962	Lad.	Bueno	C	D	2
19	Casa	1973	Lad.	Bueno	C	D	2
20	Edificio de Viv.	1991	C.A.	Muy Bueno	B	D	6
22	Edificio de Viv.	1999	C.A.	Muy Bueno	B	D	5
23	Edificio de Viv.	1997	C.A.	Muy Bueno	B	D	7

Manzana 23

Lote	Tipo(s) de Usos	Año(s) de Contrucc.	Material	Estado	Muros	Techo	Pisos
1	Casas	1944,1953,1921	Adob.	Reg.	F,D,F	H,D,F	1,2,2
2	Casa	1924	Adob.	Reg.	F	F	1
3	Casa	1933	Adob.	Bueno	F	H,D,F	1
4	Quinta	1952-1988	Adob.	Bueno	F	F	1-2
5	Quinta	1942-1950	Lad.	Reg.-Buena	C-D	D	1-4
6	Casa	1930	Adob.	Reg.	F	F	1
7	Quinta	1940-1950	Lad.	Reg-Malo	C-D-F	D-H	1
8	Quinta	1953	Lad.	Bueno	C	D	2
9	Casa	1950	Lad.	Reg.	C	D	1-3
10	Casa	1951	Adob.	Reg.	F	F	1
12	Casa	1949	Lad.	Reg.	C	D,C	2
13	Casa	1915	Adob.	Muy Malo	F	H,D,F	1
14	Colegio	1998	C.A.	Bueno	B	D	3
15	Casas	1948	Adob.	Reg.	F	F	1
16	Casa	1948	Adob.	Reg.	F	F	1

Manzana 25

Lote	Tipo(s) de Usos	Año(s) de Contrucc.	Material	Estado	Muros	Techo	Pisos
1	Viv. Prop Horizontal	1946	Lad.	Bueno	D	D	1-3
2	Casa	1946	Lad.	Bueno	C	D	3
4	Casa	1947	Adob.	Reg	F	F	1
5	Casa	1943	Adob.	Reg	F	G	1
6	Casa	1963	Lad.	Bueno	C	D	3
7	Casa	1944,1968	Adob.	Reg,Malo	F	H	2
8	Edificio de Viv.	1991	C.A.	Bueno	B	D	4
9	Edificio de Viv.	1958	Lad.	Reg.	C	D	4
10	Casas	1958,1953,1950	Lad.	Reg.	C,D,C	D	3,3,2
11	Casa	1938	Lad.	Reg.	D	D	2
12	Quinta	1947-1974	Lad.	Reg.	C	D	2
13	Quinta	1940-1948	Lad.	Reg.	C	D	2

Manzana 26

Lote	Tipo(s) de Usos	Año(s) de Contrucc.	Material	Estado	Muros	Techo	Pisos
1	Casa	1952	Adob.	Reg.	F	F	1
2	Casas	1942	Adob.	Reg-Malo	F	F	1-2
3	Casas	1948	Adob.	Reg-Malo	F	H	1
4	Quinta	1950	Adob.	Reg-Malo	F	F	1
5	Quinta	1910-1926,1960	Adob,Lad.	Reg-Malo,Reg.	F,C	G-F,D	1,3
6	Casas	1926	Adob.	Reg-Malo	F	G	1
7	Casa	1910	Adob.	Reg.	F	F	1
8	Casa	1953	Adob.	Reg.	F	F	1
9	Casas	1953	Adob.	Reg.	F	F	1
10	Casa	1961-1994	Lad.	Bueno	C	D	3

Manzana 27

Lote	Tipo(s) de Usos	Año(s) de Contrucc.	Material	Estado	Muros	Techo	Pisos
1	Ferretería	1972	Adob.	Reg.	F	F	1
2	Casa	1972	Lad.	Bueno	C	D	4
3	Quinta	1940	Adob.	Reg.	F	F	1
4	Casa	1934,1950	Adob.	Reg.	F	F,D	2
5	Consultorio,Vivienda	1950	Adob.	Reg.	F	F	1,2
7	Casas	1927,1986	Adob,Lad	Reg,Bueno	F,C	H,D	3
8	Viv. Prop. Horizontal	1962	Lad.	Bueno	C	D	1
9	Viv. Prop. Horizontal	1946	Lad.	Bueno	C	D	2
10	Quinta	1956	Lad.	Reg.	C	D	1
12	Quinta	1938	Lad.	Reg.	C-D	D-F	1-2
13	Botica	1928	Lad.	Bueno	C	F	1
14	Casa	1932	Lad.	Reg.	D	D	1
15	Casa	1928	Adob.	Reg.	F	F	1

Manzana 29

Lote	Tipo(s) de Usos	Año(s) de Contrucc.	Material	Estado	Muros	Techo	Pisos
1	Casas, Negocio	1949	Adob.	Reg,Mala	F	F	1
2	Casas	1945	Lad.	Reg.	C	D	1
3	Casa	1966	Lad.	Bueno	C	D	3
4	Casa	1976	Lad.	Bueno	C	D	3
5	Casa	1972	Lad.	Reg.	D	G	1
6	Casa	1952	Adob.	Reg.	F	H	1
7	Casas	1969,1943	Lad,Adob.	Reg.	C,F	D,H	2,1
8	Quinta	1970	Lad.	Bueno	C	D	2
9	Casa	1957	Lad.	Bueno	C	D	1
10	Casas	1985	Lad.	Reg.	C	D	2
11	Casas	1984	Lad.	Bueno	D	H	2
12	Edificio	1994	Lad.	Bueno	C	C	5
13	Quinta	1948	Adob.	Reg.	F	F	1
15	Quinta	1938	Adob.	Reg.	F	H	1
16	Casas	1929,1991	Adob,Lad	Reg,Bueno	F	G	1

Manzana 30

Lote	Tipo(s) de Usos	Año(s) de Contrucc.	Material	Estado	Muros	Techo	Pisos
1	Bodega,Casa	1967	Lad.	Reg.	C	G,D	1,2
2	Taller	1948,1980,1984	Lad.	Bueno	C	D	1
3	Quinta	1957	Lad-Adob.	Reg.	C-F	D-G-H	3
4	Casa	1930	Adob.	Bueno	F	F	1
5	Casa	1922	Adob.	Reg.	F	H	1
6	Casa	1954	Adob.	Reg.	F	F	1
7	Casa	1953	Adob.	Reg.	F	G	1
8	Casa	1923	Adob.	Reg.	F	F	1
9	Casa	1928	Adob.	Reg.	F	F	1
10	Casa	1938	Adob.	Reg.	F	F	1
11	Taller	1937	Adob.	Reg.	F	G	1
12	Edificio	1960	Lad.	Reg.	C	D	3
13	Taller	1950	Adob.	Reg.	H	G	1
14	Edificio	1966	C.A..	Muy Bueno	B	D	4
15	Quinta	1936	Adob.	Reg-Malo	F	H	1
16	Edificio	1998	C.A..	Muy Bueno	B	D	4
18	Casas	1950,1996-1998	Adob,Lad.	Reg,Bueno	F,C	H,D	1,2

Manzana 32

Lote	Tipo(s) de Usos	Año(s) de Contrucc.	Material	Estado	Muros	Techo	Pisos
1	Casa	1950	Lad.	Bueno	C	D	2
2	Casa	1970	Lad.	Bueno	C	D	3
3	Tienda	1971	Lad.	Bueno	C	D	3
4	Taller	1971	Lad.	Bueno	C	D	3
5	Taller	1974	Lad.	Bueno	C	D	3
6	Casa	1942	Adob.	Reg-Malo	F	F	1
7	Taller	1980	Lad.	Bueno	C	D	3
9	Casa	1972	Lad.	Bueno	C	D	1
10	Edificio	1981-1986	C.A.	Bueno	B	D	8
12	Edificio	1970	Lad.	Bueno	C	D	2
13	Casa	1965	Lad.	Reg.	C	D	3

Manzana 33

Lote	Tipo(s) de Usos	Año(s) de Contrucc.	Material	Estado	Muros	Techo	Pisos
1	Colegio	1968	Lad.	Bueno	C	D	2
2	Quinta	1964	Lad-Adob.	Reg.	D,C	F	1
3	Corralón,Casa	1964,1982	Adob,Lad.	Reg,Bueno	F,C	G,D	1
4	Casa	1942	Adob.	Malo	F	G	1
5	Casa	1942	Adob.	Reg.	F	F	1
8	Casa	1952	Adob.	Reg.	F	F	1
10	Casa	1945	Adob.	Reg.	F	F	1
11	Casa	1960	Lad.	Bueno	C	D	3
12	Casa	1903	Adob.	Reg.	F	F	1
13	Quinta	1960	Lad.	Bueno	D	D	3
14	Quinta	1951	Lad.	Bueno	C	D	3
15	Quinta	1950	Lad.	Bueno	C	D	3

Manzana 34

Lote	Tipo(s) de Usos	Año(s) de Contrucc.	Material	Estado	Muros	Techo	Pisos
1	Casas	1941	Adob.	Bueno	F	F	1
2	Quinta	1943-1964	Adob.	Malo	F	F	1
3	Quinta	1960	Lad-Adob	Reg.	D-F	G-F	1
4	Templo	1952	Lad.	Reg.	C	D	2
5	Casa,Mueblería	1961,1955	Lad.	Reg.	C	D	3,2
6	Casas,Mercado	1947,1996	Adob-Lad.	Reg.	F-C	G-D	1
7	Casa,Tienda	1977	Lad.	Bueno	C	D	1,2
8	Casa	1950,1990	Adob.	Reg.	F	G,F	2
9	Casas	1942	Lad.	Reg.	C	D	2
10	Casa	1921	Adob.	Reg.	F	F	1
11	Casas	1962	Lad.	Reg.	C	D	3
12	Casa	1965	Lad.	Reg.	C	D	2
13	Casa	1957	Lad.	Reg.	C	D	2
14	Casa	1964	Lad.	Reg.	C	D	3
15	Casa	1945	Adob.	Malo	F	F	2
16	Casa	1990	Lad.	Muy Bueno	C	D	3
17	Casa	1965	Lad.	Reg.	C	D	3
18	Casas	1954	Lad.	Bueno	C	D	2
19	Quinta	1943-1999	Lad.	Bueno	C	D	1-4
21	Casa	1965	Lad.	Reg.	C	D	3
22	Casas	1948	Lad.	Bueno	C	D	2
23	Club	1952	Lad.	Reg.	C	D	2
24	Quinta	1957-1990	Lad.	Reg.	C	D	1-2
25	Casa	1975	Lad.	Reg.	C	D	3
26	Instalac. Ascensores	1995	Lad.	Bueno	C	D	3

Manzana 39

Lote	Tipo(s) de Usos	Año(s) de Contrucc.	Material	Estado	Muros	Techo	Pisos
1	Casa	1977	Lad.	Bueno	C	D	2
2	Casa	1965(1,2),1987	Lad.	Bueno	C(1,2),C	D(1,2),G	3
3	Casa	1970(1,2),1986	Lad.	Bueno	C(1,2),C	D(1,2),G	3
4	Casa	1967	Lad.	Bueno	C	D	3
5	Casa	1969,1978	Lad.	Bueno	C	D	2
6	Casa	1973	Lad.	Bueno	C	D	2
7	Casa	1966	Lad.	Bueno	C	D	2
8	Casa	1986	Lad.	Bueno	C	D	3
9	Casa	1981	Lad.	Bueno	C	D	3
10	Casa	1981	Lad.	Bueno	C	D	3
11	Casa	1976	Lad.	Bueno	C	D	2
12	Casa	1980	Lad.	Bueno	C	D	3
13	Casa	1982	Lad.	Bueno	C	D	3
14	Casa	1973	Lad.	Bueno	C	D	3
15	Casa	1969	Lad.	Bueno	C	D	2
16	Casa	1982	Lad.	Bueno	C	D	2
17	Casa	1970	Lad.	Bueno	C	D	2
18	Casa	1965	Lad.	Bueno	C	D	3
19	Casa	1992	Lad.	Bueno	C	D	2
20	Casa	1967	Lad.	Bueno	C	D	2
21	Casa	1967	Lad.	Bueno	C	D	3
22	Casa	1967	Lad.	Bueno	C	D	3
23	Casa	1965	Lad.	Bueno	C	D	2
24	Casa	1968	Lad.	Bueno	C	D	3
25	Casa	1967	Lad.	Bueno	C	D	3
26	Casa	1972	Lad.	Bueno	C	D	3
27	Casa	1970	Lad.	Bueno	C	D	3
28	Casa	1973	Lad.	Bueno	C	D	2
29	Casa	1986	Lad.	Bueno	C	D	3
30	Casa	1975	Lad.	Bueno	C	D	3
31	Casa	1967	Lad.	Bueno	C	D	3
32	Casa	1967	Lad.	Bueno	C	D	3
33	Casa	1967	Lad.	Bueno	C	D	2
34	Casa	1967	Lad.	Bueno	C	D	2
35	Casa	1980	Lad.	Bueno	C	D	3
36	Casa	1976	Lad.	Bueno	C	D	3
37	Casa	1981	Lad.	Bueno	C	D	2

Manzana 40

Lote	Tipo(s) de Usos	Año(s) de Contrucc.	Material	Estado	Muros	Techo	Pisos
1	Edificio	1963	C.A.	Bueno	B	D	2
2	Casa	1993	Lad.	Reg.	C	D	1
3	Casa	1928	Adob.	Reg.	F	G	1
5	Quinta	1956	Lad.	Bueno	C	D	2
6	Quinta	1954	Adob.	Reg.	F	F	1
7	Casa	1967	Adob.	Reg.	F	G	1
8	Quinta	1919	Adob.	Reg-Malo	F	H	1
9	Edificio de Viv.	1956	Lad.	Bueno	C	D	4
11	Quinta	1939-1999	Adob-Lad.	Reg-Bueno	F-C	H-D	1-2
12	Casas	1945,1960	Adob.	Reg.	F	H	1
13	Casa	1944	Adob.	Reg.	F	H	1
14	Quinta	1963	Lad.	Bueno	C	D	1-3
15	Quinta	1940	Adob.	Reg.	F	F	1
16	Quinta	1985-1998	Lad.	Bueno	C	D	2-3
18	Casas	1961	Lad.	Bueno	C	D	1-2
19	Casa	1968	Lad.	Bueno	C	D	3
20	Colegio	1962-1997	Lad.	Bueno	C	D	4
22	Casas	1982-1983	Lad.	Bueno	C	D	2-3
24	Casa	1927	Adob.	Reg.	F	F	1
25	Casa	1968	Lad.	Bueno	C	D	3
26	Casa	1923	Adob.	Reg.	F	F	1
27	Casa	1921	Adob.	Reg.	F	H	1
29	Casa	1968	Lad.	Bueno	C	D	3
30	Casa	1968	Lad.	Bueno	C	D	3
31	Casa	1968	Lad.	Bueno	C	D	3
32	Casa	1968	Lad.	Bueno	C	D	3
34	Casas	1976,1997,1997	Adob,Lad	Reg,Bueno	F,C	G,D	1,2,3
35	Casa	1936	Adob.	Reg.	F	H	1

Manzana 41

Lote	Tipo(s) de Usos	Año(s) de Contrucc.	Material	Estado	Muros	Techo	Pisos
1	Casas	1959,1960	Lad.	Bueno,Reg.	C,D	D	4,3
2	Casa	1960	Lad.	Bueno.	D	D	2
3	Casa	1958	Adob.	Reg.	F	F	1
4	Casas	1962,1999	Lad.	Bueno	C,D	D	2
5	Quinta	1945	Adob.	Reg.	F	F	1
6	Quinta	1938	Adob.	Reg.	F	G	1
8	Taller	1970	Lad.	Reg.	C	G	1
9	Casa	1955	Lad.	Reg.	D	D	3
10	Quinta	1961-1992	Adob-Lad	Reg-Bueno	F-C	G-D	1-3
13	Quinta	1964	Adob.	Reg.	F	H	1
14	Casas	1947,1982	Lad.	Reg,Bueno	D,C	H,D	1,2
15	Quinta	1958-1990	Lad.	Bueno	C	D	1-3
16	Casas	1967	Lad.	Reg.	D	D	2
17	Quinta	1960	Lad.	Bueno	C	D	1

Manzana 43

Lote	Tipo(s) de Usos	Año(s) de Contrucc.	Material	Estado	Muros	Techo	Pisos
1	Mueblería	1937	Adob.	Malo	F	H	1
2	Quinta	1954	Adob.	Reg.	F	G	1
3	Quinta	1953	Adob.	Reg.	F	H	1
4	Quinta	1948	Adob.	Reg.	F	H	1
5	Casas,Taller	1952	Lad.	Reg,Bueno	C	D	3,2
7	Quinta	1962	Adob.	Reg.	F	H	1
8	Callejón	1929	Adob.	Reg-Malo	F	H-F	1
10	Casa, Edificio	1990,1970	C.A.,Lad.	Muy Bueno	B,C	D	1,2
12	Casa	1971	Lad.	Bueno	D	D	1
13	Quinta	1990-1999	Lad.	Bueno	C	D	2-3
14	Callejón	1944	Adob.	Reg.	F	F	1

Manzana 45

Lote	Tipo(s) de Usos	Año(s) de Contrucc.	Material	Estado	Muros	Techo	Pisos
1	Casa	1968	Lad.	Bueno	C	D	2
2	Casa	1970	Lad.	Bueno	C	D	2
3	Casa	1968	Lad.	Bueno	C	D	3
4	Casas	1959-1990	Lad.	Bueno	C	D	3
5	Casa	1971	Lad.	Bueno	C	D	2
6	Casa	1964	Lad.	Bueno	C	D	2
7	Casa	1968	Lad.	Reg.	C	D	1
8	Quinta	1970	Lad.	Bueno	C	D	3
9	Casa	1959	Lad.	Bueno	C	D	3
10	Casa	1957	Lad.	Bueno	C	D	2
11	Casa	1966	Lad.	Bueno	C	D	2
12	Quinta	1960-1982	Lad.	Reg.	C	D	4-3
13	Edificio de Viv.	1961	Lad.	Reg.	C	D	2
15	Casas	1955-1959	Lad.	Reg.	C	D	3
16	Embajada de Mex.	1967	Lad.	Bueno	C	D	1
17	Edificio	1999	C.A.	Muy Bueno	B	D	5
18	Estacionamiento	1993	C.A.	Muy Bueno	B	D	1
19	Edificio	1995	C.A.	Muy Bueno	B	D	6
20	Edificio	1995	C.A.	Muy Bueno	B	D	6
21	Edificio de Viv.	1993	C.A.	Muy Bueno	B	D	6
22	Casa	1964	Lad.	Bueno	C	D	2

Manzana 48

Lote	Tipo(s) de Usos	Año(s) de Contrucc.	Material	Estado	Muros	Techo	Pisos
1	Casa	1957	Lad.	Bueno	C	D	3
2	Edificio	1961	Lad.	Bueno	C	D	3
4	Casa, Oficinas	1955, 1958	Lad.	Bueno	C	D	2,3
6	Casa	1963	Lad.	Bueno	C	D	3
7	Casa	1958-1962	Lad.	Bueno	C	D	2-3
9	Quinta	1946	Lad.	Reg.	D	D	2
10	Casa	1956, 1958	Lad.	Bueno	C	D	2
12	Edificio de Oficinas	1967	Lad.	Bueno	B	D	3
14	Edificio	1957	Lad.	Bueno	C	D	3
16	Casa	1968	Lad.	Bueno	C	D	2
17	Quinta	1960	Lad.	Bueno	C	D	3
18	Casas	1953-1999	Lad.	Bueno	C	D	2-3
19	Edificio de Viv.	1970	C.A.	Bueno	B	D	4
23	Quinta	1960	Lad.	Bueno	C	D	3-4

Manzana 51

Lote	Tipo(s) de Usos	Año(s) de Contrucc.	Material	Estado	Muros	Techo	Pisos
1	Casa	1930	Lad.	Reg.	D	H	1
2	Casa	1996	Lad.	Bueno	C	D	2
3	Casa	1979	Lad.	Bueno	C	D	3
4	Casa	1981	Lad.	Bueno	C	D	2
5	Casa	1935	Adob.	Reg.	F	H	1
6	Casa	1956	Lad.	Reg.	C	D	1

Manzana 53

Lote	Tipo(s) de Usos	Año(s) de Contrucc.	Material	Estado	Muros	Techo	Pisos
1	Casas	1974-1975	Lad.	Bueno-Reg	C	D	3-2
2	Casas	1944	Lad.	Reg.	C	D	2
3	Casa	1953	Adob.	Reg.	F	F	1
5	Casa	1930	Lad.	Reg.	C	D	3
6	Quinta	1966	Adob.	Reg.	F	H	1
9	Colegio Inicial	1971, 1999	Lad, Adob	Reg-Bueno	D,E	D,G	2,1
10	Casa	1940	Lad.	Reg.	C	D	3
11	Casa	1940	Lad.	Reg.	C	D	3
12	Casa	1964	Lad.	Bueno	C	D	3
13	Casa	1974	Lad.	Bueno	C	D	3
14	Casa	1974	Lad.	Bueno	C	D	2
15	Quinta	1953	Adob.	Reg.	F	F,G	1
16	Casa	1960	Adob.	Reg.	F	F	1
18	Casa	1953	Adob.	Reg.	F	F	2

Manzana 56

Lote	Tipo(s) de Usos	Año(s) de Contrucc.	Material	Estado	Muros	Techo	Pisos
1	Instituto	1975-1996	Lad.	Bueno	C	D	2
2	Colegio	1996	Lad.	Muy Bueno	C	D	2

Manzana 57

Lote	Tipo(s) de Usos	Año(s) de Contrucc.	Material	Estado	Muros	Techo	Pisos
1	Casa	1968	Lad.	Bueno	C	D	2
2	Casa	1968	Lad.	Bueno	C	D	2
3	Casa	1968	Lad.	Bueno	C	D	2
4	Iglesia	1983	C.A.	Bueno	B	D	2
6	Casa	1927	Lad.	Bueno	C	D	3
8	Fábrica	1946	Lad.	Reg.	D	D	2
9	Casa	1940	Lad.	Reg.	D	D	2
10	Casa	1949	Lad.	Reg.	D	D	2
11	Casa	1950	Lad.	Reg.	D	D	3
12	Casa	1968	Lad.	Bueno	C	D	2
13	Casa	1968	Lad.	Bueno	C	D	2
14	Casa	1968	Lad.	Bueno	C	D	2
15	Casa	1969	Lad.	Reg.	C	D	2
16	Casa	1968	Lad.	Bueno	C	D	2
17	Casa	1968	Lad.	Reg.	C	D	2
18	Casa	1968	Lad.	Bueno	C	D	3

Manzana 61

Lote	Tipo(s) de Usos	Año(s) de Contrucc.	Material	Estado	Muros	Techo	Pisos
1	Casa	1963	Lad.	Bueno	C	D	2
2	Casa	1966	Lad.	Bueno	C	D	2
3	Casa	1970	Lad.	Bueno	C	D	3
4	Almacén	1960	Lad.	Reg.	C	D	2
5	Casas	1958	Lad.	Bueno	D,C	D,D	3,1
6	Casa	1927	Adob.	Reg.	F	F	1
7	Quinta	1943-1980	Lad-Adob	Bueno-Reg.	C-E	D-F	2
8	Casas	1942	Adob-Lad	Reg-Bueno	F-D	F-F	1-2
10	Quinta,Casas	1933,1948	Adob,Lad	Reg,Bueno	F,C	H,D	1
12	Quinta	1950	Adob.	Reg.	F	H	1
13	Callejón	1944	Adob.	Reg.	F	H	1
14	Edificio	1999	C.A.	Muy Bueno	B	D	4
16	Casa	1975	Lad.	Bueno	C	D	2
17	Casa	1974	Lad.	Bueno	C	D	2
18	Casa	1975	Lad.	Bueno	C	D	2
19	Casa	1976	Lad.	Bueno	C	D	2
20	Casa	1978	Lad.	Bueno	C	D	2
21	Quinta	1959-1976	Lad.	Bueno	C	D	2-3
22	Casa	1959	Lad.	Bueno	C	D	3
23	Servicios Médicos	1974	Lad.	Bueno	C	D	2
25	Coliseo	1949-1996	Lad.	Bueno	C	D	1-2

Manzana 63

Lote	Tipo(s) de Usos	Año(s) de Contrucc.	Material	Estado	Muros	Techo	Pisos
1	Casa, Tapicería	1912, 1990	Adob.	Reg.	F	H	2,1
2	Casa	1967	Adob.	Malo	F	H	1
3	Quinta	1959	Adob.	Reg.	F	F	1
4	Casas	1963	Lad.	Bueno	C	D	3
6	Quinta	1959	Lad.	Reg.	C	D	2
7	Rencauche	1968	Lad.	Bueno	D	G	1
9	Factoría	1965	Lad.	Bueno	C	D	1
11	Taller	1965	Lad.	Bueno	C	D	1
12	Casa	1963	Lad.	Reg.	C	D	1
13	Ferretería	1976	Adob.	Reg.	F	H	1
14	Taller	1977	Lad.	Bueno	C	D	1
16	Casas	1985	Lad.	Bueno	C	D	3
18	Casas	1977-1964	Lad.	Bueno	C	D	2-3
20	Colegio	1935	Adob.	Reg.	F	H	2
21	Desocupado	1940	Adob.	Reg.	F	H	1
22	Taller	1993(1,2), 1999	Lad(1,2), C.A.	Bueno	B,B,C	B,B,C	3

Manzana 64

Lote	Tipo(s) de Usos	Año(s) de Contrucc.	Material	Estado	Muros	Techo	Pisos
1	Casas	1951-1957	Lad.	Bueno	D	D	3-2
2	Casa	1958	Lad.	Bueno	C	D	2
3	Casa	1967	C.A.	Muy Bueno	B	D	3
4	Casas	1941,1999	Lad.	Reg,Bueno	C	D	2,1
6	Colegio,Casa	1979,1980	Lad.	Bueno	C	D	1,2
7	Casa	1979	Lad.	Bueno	C	D	2
8	Casa	1959	Lad.	Bueno	C	D	3
9	Casa	1974	Lad.	Bueno	C	D	3
10	Casa	1973	Lad.	Bueno	C	D	3
11	Casa	1974	Lad.	Bueno	C	D	3
12	Casa	1974	Lad.	Bueno	C	D	3
13	Casa	1974	Lad.	Bueno	C	D	3
14	Casa	1974	Lad.	Bueno	C	D	3
15	Casa	1974	Lad.	Bueno	C	D	3
16	Casa	1974	Lad.	Bueno	C	D	3
17	Casa	1974	Lad.	Bueno	C	D	2
18	Casa	1974	Lad.	Bueno	C	D	3
19	Quinta	1965	Lad.	Bueno	C	D	1
20	Quinta	1968	Lad.	Bueno	C	D	2
21	Casa	1969	Lad.	Bueno	D	D	1
22	Casa	1970	Lad.	Reg.	C	D	3
25	Quinta	1966	Lad.	Bueno	D	D	2
27	Edificio	1970	C.A.	Bueno	B	D	6
28	Quinta	1965	Lad.	Bueno	C	D	1-3
30	Quinta	1965	Lad.	Bueno	C	D	2

Manzana 65

Lote	Tipo(s) de Usos	Año(s) de Contrucc.	Material	Estado	Muros	Techo	Pisos
1	Edificio de Viviendas	1976	C.A.	Bueno	B	D	5

Sector 2

Manzana 1

Lote	Tipo de Usos	Año(s) de Contrucc.	Material	Estado	Muros	Techo	Pisos
1	Colegio	1986	Lad.	Bueno	C	G	1
3	Tienda	1971	Lad.	Reg.	C	G	1
5	Taller	1978, 1999, 1999	Lad, Lad, Adob.	Bueno	D, D, E	C, F, F	3
7	Taller	1971, 1995, 1995	Lad.	Bueno	C, C, E	C, F, H	3
8	Casa	1948	Lad.	Bueno	C	D	1
9	Taller	1960	Lad.	Reg.	C	G	1
10	Casa	1963	Adob.	Reg.	F	G	1
11	Casa	1948	Adob.	Reg.	F	G	1
12	Casa	1949	Adob.	Reg.	F	G	1
13	Quinta	1958, 1966	Lad-Adob	Reg-Malo	F-D	H-G	1
14	Quinta	1958	Lad-Adob	Reg-Malo	F-C	D-H	1
16	Quinta	1953	Adob.	Reg.	F	H	1
20	Callejón	1966-1951	Adob.	Reg.	F	H-G	1
25	Taller	1966	Lad.	Bueno	C	G	1
27	Taller	1986	Lad.	Reg.	D	G	1

Manzana 2

Lote	Tipo(s) de Usos	Año(s) de Contrucc.	Material	Estado	Muros	Techo	Pisos
1	Restaurante	1945	Adob.	Reg.	F	H	1
2	Tienda	1985	Lad, Adob	Bueno	C, D	D, H	2
3	Taller	1985, 1989	Adob, Lad	Reg.	F, D	G, D	2
7	Casa	1985, 1987	Lad, Adob	Bueno	C	D	2
9	Fábrica	1967	Adob	Reg.	E	G	1
10	Taller-Industr-Peña	1930	Adob	Reg.	F	G	1
12	Tienda-Taller	1961	Adob	Reg.	F	H	1
15	Casa	1950	Adob	Reg.	F	H	1
17	Viv.Prop.Horiz	1965	Lad.	Reg.	D	D	1
19	Casa	1989, 1990	Lad, Adob	Buen, Reg.	F, C	G, H	2
21	Casa	1989	Adob.	Reg.	F	G	1

Manzana 3

Lote	Tipo(s) de Usos	Año(s) de Contrucc.	Material	Estado	Muros	Techo	Pisos
1	Casa	1940	Adob.	Reg.	F	H	1
2	Casa	1945, 1970	Lad, Adob	Reg.	D, H	G, H	2
3	Casa	1963	Adob.	Reg.	F	H	1
4	Callejón	1969	Adob.	Reg.	F	G	1
5	Quinta	1973	Adob, Lad	Reg.	F	F, H	1
6	Quinta	1958-1960	Lad-Adob	Buen-Reg	C	D	1
9	Casa	1944	Lad.	Reg.	D	F	1
11	Quinta	1964-1967	Adob-Lad	Reg.	F	G	1
12	Quinta	1964-1968	Adob-Lad	Reg.	F	G	1
18	Casa	1956	Adob.	Reg.	F	H	1
21	Callejón	1972	Adob.	Reg.	F	H	1
25	Tienda	1969	Lad.	Reg.	D	E	1

Manzana 4

Lote	Tipo(s) de Usos	Año(s) de Contrucc.	Material	Estado	Muros	Techo	Pisos
1	Casa	1950	Lad.	Reg.	C	D	2
2	Casa	1950, 1973	Lad.	Bueno	C	D	2
3	Viv.Prop.Horiz	1950	Lad.	Bueno	C	D	2
7	Edificio	1989	C.A.	Muy Bueno	B	D	3
9	Casa	1965	Adob.	Reg.	D	F	1
10	Edificio	1965	C.A., Lad	Bueno	B	D	4
12	Quinta	1923	Adob.	Reg.	F	F	1
13	Quinta	1990-1988-1960	Lad-Adob.	Buen-Reg	C-D	F	1-2
15	Quinta	1951-1953	Lad-Adob.	Reg.	C	F	1-2
17	Quinta	1948	Adob, Lad	Bueno	F-C	F	1-2
18	Quinta	1949	Adob.	Reg.	F-C	F-D	1
19	Casa	1935	Adob.	Malo.	F	G	1
23	Tienda, Casa	1993, 1988	Lad.	Bueno	C	D	2

Manzana 5

Lote	Tipo(s) de Usos	Año(s) de Contrucc.	Material	Estado	Muros	Techo	Pisos
1	Casa	1935	Adob.	Reg.	I	H	1
2	Casa	1965	Lad.	Reg.	C	D	1
5	Tienda	1965	Adob.	Bueno	F	H	1
6	Casa	1970,1970,1980	Lad.	Reg.	C	D	3
7	Quinta	1935	Adob.	Reg-Malo	F	F-H	1
10	Casa	1945	Adob.	Reg.	F	H	1
11	Quinta	1960	Adob.	Reg.	F	H	1
12	Quinta	1937	Adob-Lad	Reg.	F	H	1
13	Quinta	1940	Adob	Reg.	-F	H	1
14	Quinta	1957	Lad.	Reg.	D	H	1
16	Casa	1937	Adob.	Reg.	F	H	1
19	Tienda	1964	Lad.	Reg.	C	D	2
21	Quinta	1968-1972	Lad.	Buen-Reg.	C	D	1
22	Callejón	1957	Adob.	Malo	F	H-I	1

Manzana 6

Lote	Tipo(s) de Usos	Año(s) de Contrucc.	Material	Estado	Muros	Techo	Pisos
1	Casas	1948	Adob.	Reg.	F	F-G	1
2	Quinta	1951	Lad.	Buen-Reg.	C-D	D-E	1
3	Casa	1950	Adob.	Reg.	F	H	1
5	Quinta	1953-1962	Adob.	Malo	F	H	1
6	Tienda	1953	Lad.	Reg.	C	D	1
7	Quinta	1956	Adob.	Malo	F	F-G	1
9	Constructora.	1975	C.A.	Bueno	B	D	2
10	Casa	1943	Adob.	Bueno	F	G	3
13	Taller	1965	Adob.	Malo	F	H	1

Manzana 7

Lote	Tipo(s) de Usos	Año(s) de Contrucc.	Material	Estado	Muros	Techo	Pisos
1	Taller	1942	Lad.	Malo	C	H	1
2	Taller	1942	Lad.	Malo	C	H	1
3	Taller	1942	Lad.	Malo	C	H	1
5	Taller	1942	Lad.	Malo	C	H	1
6	Taller	1942	Lad.	Bueno	C	D,H	2
8	Taller	1942	Lad.	Reg.	C	G,E	2
10	Taller	1942	Lad.	Reg.	C	G	1
12	Factoría	1942	Lad.	Reg.	C	G	1
15	Taller	1942	Lad.	Reg.	C	E	1
16	Taller	1942	Adob.	Malo	F	G	1
17	Factoría	1942	Lad.	Reg.	C	G	1
18	Oficinas	1985	Lad.	Reg.	C,H	G	2
19	Taller	1985	Lad.	Bueno	C	E	1
23	Taller	1940	Lad.	Bueno	C	G	1
25	Quinta	1942	Adob.	Malo	F-C	H	1

Manzana 9

Lote	Tipo(s) de Usos	Año(s) de Contrucc.	Material	Estado	Muros	Techo	Pisos
1	Edificio	1968	Lad.	Reg.	C	D	2
2	Casa	1959	Adob.	Reg.	F	F	1
4	Quinta	1968	Lad.	Reg.	C	D	1
5	Casa	1951	Lad.	Bueno	C	D	1
7	Quinta	1941-1972	Adob.	Buen-Reg.	F	H	1
8	Casa	1941	Adob.	Reg.	F	H	1
10	Casa	1939	Adob.	Reg.	F	H	1
12	Casa	1986	Lad.	Bueno	C	D	3
13	Edificio	1947	C.A.	Bueno	B	D	3
15	Quinta	1945	Adob.	Reg.	F	H-F	1
16	Quinta	1955	Adob.	Reg.	F	H-F	1
17	Quinta	1947	Adob.	Reg.	F	H-F	1
21	Casa	1955	Lad.	Reg.	C	D	2
24	Casa	1965	Lad.	Bueno	C	D	3
25	Quinta	1943	Adob.	Reg.	F	H	1
28	Casa	1976	Adob.	Reg.	F	H	1

Manzana 10

Lote	Tipo(s) de Usos	Año(s) de Contrucc.	Material	Estado	Muros	Techo	Pisos
2	Quinta	1949	Adob.	Reg.	F	F	1
3	Quinta	1950	Adob.	Reg.	F	H	1
4	Taller	1990	Lad.	Bueno	C	I	1
5	Tienda	1990	Lad.	Bueno	C	F	1
6	Quinta	1921	Adob.	Reg.	F	F	1
8	Casa	1922	Adob.	Reg.	F	F	1
10	Quinta	1975	Lad.	Bueno	F-C	H-D	1
11	Casa	1920	Adob.	Reg.	F	H	1
12	Quinta	1926	Adob.	Reg.	F	H	1
14	Quinta	1960	Adob.	Reg.	F	H	1
17	Quinta	1950	Adob.	Reg.	F	F	1
19	Quinta	1925	Adob.	Reg.	F	H	1

Manzana 11

Lote	Tipo(s) de Usos	Año(s) de Contrucc.	Material	Estado	Muros	Techo	Pisos
1	Casa	1980	Lad.	Bueno	C	D	2
1	Casa	1980	Lad.	Bueno	C	D	2
3	Casa	1954, 1983	Adob., Lad.	Bueno	C, F	D, H	2
4	Quinta	1923	Adob.	Reg.	E	H	1
5	Casa	1924	Adob.	Malo	F	F	1
6	Quinta	1980	Lad.	Reg.	C	D	1
7	Casa	1923	Adob.	Malo	F	F	1
8	Corralón	1969	Adob.	Reg.	F	H	1
11	Casa	1986	Lad.	Reg.	C	D	1

Manzana 12

Lote	Tipo(s) de Usos	Año(s) de Contrucc.	Material	Estado	Muros	Techo	Pisos
1	Grifo	1966	Lad.	Bueno	C	D	2
2	Quinta	1957-1969	Lad.	Reg.	C	G-D	1-3
3	Taller	1957	Lad.	Reg.	C	G	1
5	Taller	1957	Lad.	Reg.	C	G	1
6	Taller	1957	Lad.	Reg.	C	G	1
8	Casa	1979	Lad.	Reg.	D	H	1
9	Depósito	1942	Adob.	Malo	F	H	1
10	Casa	1973	Lad.	Reg.	F	F	1
11	Casa	1940	Lad.	Bueno	D	D	1
12	Casa-Tienda	1936	Adob.	Reg.	F	D	1
14	Casa	1933	Lad.	Bueno	D	D	1
15	Casa	1993	Lad.	Muy Bueno	C	D, E	2
17	Edificio	1980-1984	Lad.	Reg.	C	D	3
21	Casa	1941	Adob.	Bueno	F	F	1
23	Casa	1957	Lad.	Reg.	D	D	1
24	Taller	1968	Lad.	Reg.	C	D	1

Manzana 14

Lote	Tipo(s) de Usos	Año(s) de Contrucc.	Material	Estado	Muros	Techo	Pisos
1	Tienda	1970	Lad.	Reg.	E	H	1
2	Casa	1953	Adob.	Reg.	F	H	1
3	Quinta	1957-1994	Lad.	Reg.	C-D	F-H	1
6	Casa	1959	Lad.	Reg.	C	D, E	2
7	Callejón	1960	Adob.	Malo	F	H	1
8	Edificio	1974	Lad.	Bueno	C	D	3
10	Casa	1957	Lad.	Reg.	C	D	1
11	Casa	1957	Adob.	Reg.	F	G	1
13	Casa	1977	Lad.	Reg.	C	D	1
17	Casa	1957	Lad.	Reg.	C	D	1
19	Callejón	1930	Adob.	Reg.	F	G-H	1
21	Casa	1924	Adob.	Reg.	F	H	1
22	Casa	1958	Adob.	Malo	F	H	1
23	Casa	1946	Adob.	Reg.	F	H	1
24	Casa	1927	Adob.	Reg.	F	F	1
27	Club	1932	Adob.	Reg.	F	F	1
29	Quinta	1949-1961	Adob-Lad.	Reg.	D-C	G-D	1
30	Quinta	1956	Adobe	Reg.	F	H	1

Manzana 16

Lote	Tipo(s) de Usos	Año(s) de Contrucc.	Material	Estado	Muros	Techo	Pisos
1	Casas	1945	Lad.	Reg.	C	D	1
2	Colegio	1950	Adob.	Reg.	F	F	1
3	Casa	1959	Adob.	Reg.	F	C	2
4	Casa	1978	Lad.	Bueno	C	D	2
5	Casa	1940	Adob.	Reg.	F	H	2
6	Quinta	1940	Adob.	Reg.	F	H	1
7	Quinta	1954	Adob.	Reg.	F	H	1
9	Casas	1934	Adob.	Malo	F	H	1
10	Quinta	1966	Lad.	Bueno	C	D	1
11	Edificio	1968	Lad.	Reg.	C	D	2

Manzana 17

Lote	Tipo(s) de Usos	Año(s) de Contrucc.	Material	Estado	Muros	Techo	Pisos
1	Casa	1950	Lad.,Adob.	Reg	D	D	2
2	Casa	1952	Lad.	Reg	D	D	1
3	Casa	1950	Lad.	Reg	D	D	1
4	Casa	1950	Lad.	Bueno	D	D	1
5	Casa	1956	Lad.	Reg	D	D	3
7	Casa	1956	Lad.	Reg	C	D	1
9	Casa	1938	Lad.	Reg	D	D	2
11	Casa	1943	Lad.	Bueno	D	D	2
13	Casa	1928	Lad.	Bueno	D	D	1
14	Quinta	1950	Adob	Reg.	F	H	2
15	Quinta	1954	Adob.	Reg.	F	F	1
16	Quinta	1960	Adob.	Reg.	F	H	1
17	Quinta	1954	Adob.	Reg.	F	F	1
18	Casa	1959	Lad,Adob.	Reg.	C,E	D,G	2
20	Casa	1920	Adob.	Malo	F	H	1
21	Quinta	1940	Adob-Lad	Reg.	F-C	H-F	1
24	Corralón	1950	Adob.	Malo	F	H	1
25	Corralón	1950	Adob.	Malo	F	H	1
26	Quinta	1952	Adob.	Reg-Malo	F-C	H-F-G	1
28	Quinta	1958	Lad.	Bueno	C	D	1
30	Edificio	1963	Lad.	Bueno	C	D	3
31	Casa	1952	Lad.	Reg	D	D(1,2),E	3

Manzana 19

Lote	Tipo(s) de Usos	Año(s) de Contrucc.	Material	Estado	Muros	Techo	Pisos
1	Negocios	1960	Lad.	Bueno.	D	D	1
2	Depósito	1961	Lad.	Reg.	C	D	1
3	Ensamblaje	1961	Lad.	Reg.	C	E,D(2,3)	3
4	Casa	1940	Lad.	Reg.	D	F	1
7	Taller	1987	Lad.	Bueno.	C	D	1
8	Taller	1954	Lad.	Bueno.	C	D,E,G	3
9	Convento	1959	Lad.	Bueno.	C	D	1
10	Casa	1956	Lad.	Reg.	C	D	2
12	Casa	1966	Lad.	Reg.	C	D	2
13	Casa	1971	Lad.	Reg.	C	D	2
14	Farmacia,Casa	1959,1975	Lad.	Reg.	C	D	1

Manzana 20

Lote	Tipo(s) de Usos	Año(s) de Contrucc.	Material	Estado	Muros	Techo	Pisos
1	Taller	1989	Lad	Bueno	C	D	3
2	Quinta	1929-1971-1994	Adob-Lad.	Reg-Bueno	C-D-F	D-F-H	1
3	Casa, Depósito	1972,1945	Lad, Adob	Buen,Reg.	C,F	D,H	2,2
4	Quinta	1930	Adob.	Reg.	F	G	1
5	Quinta	1956	Lad.	Bueno	F-C	F-D	1
6	Casa, Tienda	1988,1946	Lad.	Buen,Reg.	C	H,D	1
7	Quinta	1928	Adob.	Malo	F	H	1
9	Casa	1929	Adob.	Reg.	F	F	2
10	Casa	1940	Adob.	Reg.	F	F	1

Manzana 23

Lote	Tipo(s) de Usos	Año(s) de Contrucc.	Material	Estado	Muros	Techo	Pisos
1	Casa	1962	Adob.	Reg.	F	F	1
2	Casa	1962	Lad.	Reg.	F	F	1
3	Casa	1941	Adob.	Malo	F	F	1
4	Casa	1954	Adob.	Reg.	F	F	2
6	Casa	1945	Adob.	Reg.	F	G	1
7	Casa	1950	Lad.	Reg.	D	D	2
8	Edificio	1958	Lad.	Bueno	D	D	3
9	Casa	1952	Lad.	Bueno	C	D	1
11	Casa	1989	Adob.	Reg.	F	H	1
12	Casa	1990	Lad.	Bueno	D	D,I	2
13	Tienda	1956	Adob.	Reg.	F	F	1
14	Restaurante	1934	Adob.	Reg.	F	H	1
16	Restaurante	1956	Adob.	Reg.	F	G	1
17	Restaurante	1956	Adob.	Reg.	F	F	1
18	Restaurante	1960	Adob.	Reg.	F	E	1
19	Casa,Reparac Artef.	1980,1985	Lad.,Lad	Reg,Bueno	C	D	3,2
22	Casa	1958	Adob.	Reg.	F	F	1
23	Casa	1933	Adob.	Reg.	F	H	1
24	Taller, Negocio, Casa	1976	C.A., Lad.	Reg.,Bueno	B,D	D,D	3
26	Casa	1976	Lad.	Bueno	C	D	1
27	Casa	1923	Lad.	Reg.	C	F	1
29	Colegio	1982,1984,1991	C.A., Lad.	Bueno	B(1,2),C	D,D,F	3
30	Callejón	1956	Adob.	Reg.	F	F	1

Manzana 26

Lote	Tipo(s) de Usos	Año(s) de Contrucc.	Material	Estado	Muros	Techo	Pisos
1	Casa	1933	Adob.	Reg.	F	F-H	1
2	Casa	1933	Adob.	Reg.	F	F-H	1
3	Casa	1933	Adob.	Reg.	F	F-H	1
4	Casa	1973	Lad.	Bueno	C	D	2
5	Colegio	1976	Adob,Lad	Reg,Bueno	F,D	F,D	2
6	Casa	1943,1960	Lad.	Bueno	D	D	3
10	Quinta	1965	Adob.	Reg.	F	H-G	1
11	Casa	1934	Adob.	Reg.	F	F	1
13	Casa	1954	Adob.	Reg.	F	F	1
14	Casa	1954	Adob.	Reg.	F	F	1
15	Casa	1947	Lad.	Reg.	C	D	1

Manzana 27

Lote	Tipo(s) de Usos	Año(s) de Contrucc.	Material	Estado	Muros	Techo	Pisos
1	Casa	1938	Adob.	Reg.	F	H	1
2	Casa	1908	Adob.	Muy Malo	F	H	1
3	Taller	1957	Lad.	Reg.	D	G	1
5	Casa	1943	Lad.	Bueno	C	D	2
7	Casa-Comercio	1937	Adob.	Bueno	F	F	1
8	Casa	1945	Lad.	Reg.	D	D	1
9	Casa	1943	Adob.	Reg.	F	F	1
12	Quinta	1922	Adob.	Reg.	F	F	1
15	Negodo, Casa	1939,1963	Lad, Adob.	Reg.	F,C	F,D	1
16	Quinta	1921-1977	Adob-Lad	Malo-Reg	F-D	H-F	1
17	Casa	1989	Lad.	Bueno	C	D	1
18	Quinta	1940	Adob.	Reg.	F	F	1
19	Quinta	1945	Adob.	Reg.	F-C	F-H-D	1
21	Casa	1928	Adob.	Reg.	F	F	1
22	Casa	1972	Lad.	Reg.	C	D	1
24	Casa	1917	Adob.	Reg.	F	H	1
26	Casa	1922	Lad.	Bueno	C	D	1
27	Casa	1979	Lad.	Bueno	C	D	3

Manzana 28

Lote	Tipo(s) de Usos	Año(s) de Contrucc.	Material	Estado	Muros	Techo	Pisos
1	Iglesia	1973,1976,1989	Lad,C.A.	Bueno,Reg.	C,B	D,C	3
2	Casas	1914-1920	Adob.	Reg	F	H	1
3	Casa Desocup.	1900	Adob.	Malo	F	G	1
4	Casa Desocup.	1901	Adob.	Malo	F	G	1
6	Casa	1957	Adob.	Reg	F	F	1
8	Casa	1972	Lad.	Bueno	C	D	1
9	Quinta	1926	Lad.	Reg	D,E	H,D	1
10	Casa	1943	Adob.	Reg	F	F	1
11	Casa-Negocio	1960	Lad.	Reg	C	D	1
12	Casa	1926	Adob.	Reg	F	H	1

Manzana 31

Lote	Tipo(s) de Usos	Año(s) de Contrucc.	Material	Estado	Muros	Techo	Pisos
1	Desocupada	1960	Lad.	Reg.	D	D	1
2	Quinta	1962	Adob.	Reg.	F	H	1
3	Casa	1953,1992	Lad.	Buena	C	D	2
4	Casa	1927-1950	Adob.	Reg.	F	H	1
5	Quinta	1934	Adob.	Reg-Malo	F	H	1
6	Casa	1943	Adob.	Reg.	F	H	1
7	Casa	1933	Adob.	Reg.	F	H	1
10	Corralón	1955	Adob.	Malo	F	H	1

Manzana 32

Lote	Tipo(s) de Usos	Año(s) de Contrucc.	Material	Estado	Muros	Techo	Pisos
1	Casa	1976	Lad.	Buena	C	D	1
2	Casa	1969	Lad.	Buena	C	D	3
3	Casa	1962,1977	Lad.	Reg.	C,D	D,D	2
4	Casa	1935,1958	Adob.	Reg.	F	F	1
6	Casa	1957	Adob.	Reg.	F	F	1
8	Casa	1972	Lad.	Buena	C	D	3
9	Quinta	1926	Lad.	Reg.	D,E	H,D	1
10	Casa	1943	Adob.	Reg.	F	F	1
12	Casa	1978	Lad.	Reg.	C,E	D,F	2
13	Casa	1979,1992	Adob,Lad	Reg,Buena	F,D	F,D	1
14	Casa	1980	Adob.	Malo	F	F	1
17	Quinta	1944	Adob.	Reg.	F	F	1
19	Desocupada	1962	Adob.	Reg.	F	I	1

Manzana 34

Lote	Tipo(s) de Usos	Año(s) de Contrucc.	Material	Estado	Muros	Techo	Pisos
1	Casa	1924	Adob.	Reg.	F	F	1
2	Casa	1967	Lad.	Buena	C	D	1
3	Casa	1924	Adob.	Reg.	F	F	1
4	Casa	1900	Adob.	Muy Malo	F	G	1
5	Industrias	1964,1969	Lad.	Buena	C	D	3
6	Quinta	1939-1952	Adob.	Reg.	F	F	1
10	Casa	1948	Adob.	Reg.	F	H	1
12	Casa	1900	Adob.	Reg.	F	H	1
13	Quinta	1939-1952	Adob.	Reg.	F	F	1

Manzana 37

Lote	Tipo(s) de Usos	Año(s) de Contrucc.	Material	Estado	Muros	Techo	Pisos
2	Casa	1975,1972	Lad.	Buena	C	D	3
4	Casa	1966	Lad.	Buena	C	D	2
5	Casa	1917	Adob.	Reg.	F	H	1
6	Casa	1970	Adob.	Reg.	F,C	F,D	1
7	Quinta	1943	Adob.	Reg.	F	F	1
8	Casa	1948	Adob.	Reg.	F	F	1
10	Casa	1974	Lad.	Buena	C	D	1
11	Casa	1993	Lad.	Buena	C	D	1
14	Casa	1967	Adob.	Malo	F,F	G,H	1
15	Casa	1999	Lad.	Muy Buena	C	C	3
17	Casa	1972	Adob.	Reg.	F	H	1
18	Casa	1973	Adob.	Reg.	F	F	1
20	Casa	1958	Lad.	Buena	C	D	1
22	Casa	1975	Lad.	Buena	C	D	1
23	Casa	1968	Lad.	Buena	C	D	1
24	Casa	1950	Adob.	Reg.	F	F	1
25	Casa	1950	Adob.	Reg.	F	G	1
26	Casa	1950	Adob.	Reg.	F	G	1
29	Casa	1943	Lad.	Reg.	D	F	1

Manzana 39

Lote	Tipo(s) de Usos	Año(s) de Contrucc.	Material	Estado	Muros	Techo	Pisos
1	Casas	1923	Adob	Bueno,Reg.	F	H,G	1
2	Casa	1988	Lad.	Bueno	C	D	3
3	Casa	1948(1,2), 1985(3)	Lad.	Reg.	D	D	3
5	Casa	1962	Adob	Reg.	F	F	1
6	Casa	1952	Lad.	Bueno	F	F	1
8	Casas	1967	Lad.	Bueno	C	D	1
10	Colegio	1940,1989	Adob,Lad.	Reg,Bueno	F,C	F,D	2
11	Casa	1948	Adob.	Reg.	F	F	1
13	Casas	1965,1929,1976	Adob.	Reg.	F	F	1
14	Casa	1960	Adob.	Reg.	F	F	1
16	Casas	1970	Adob,Lad	Reg.	C,D	D,F	1
18	Casas	1921	Adob.	Reg.	F	H	1

Manzana 40

Lote	Tipo(s) de Usos	Año(s) de Contrucc.	Material	Estado	Muros	Techo	Pisos
1	Quinta	1942,1943,1965	Lad-Adob	Reg.	F	G	1
2	Casa	1943	Adob.	Reg.	F	G	1
3	Playa Estac.	1990	Lad.	Bueno	C	G	1
4	Edificio de Viviendas	1983	Lad.	Bueno	C	D	2
6	Casa	1976	Lad.	Reg.	C	D	1
7	Quinta	1969	Lad.	Bueno	C	D	1
8	Casa	1950	Adob.	Reg.	F	F	1
10	Casa	1941	Adob.	Reg.	F	F	1
11	Casa Desocupada	1908	Adob.	Muy Malo	F	I	1
12	Casa	1940	Adob.	Malo	F	F	1
13	Casa	1930	Adob.	Reg.	F	F	1
14	Consultorio	1954	Adob.	Reg.	F	F	1
15	Casa	1940	Adob.	Reg.	F	F	1
16	Casa	1933	Adob.	Reg.	F	F	1
17	Casa Desocupada	1960	Lad.	Malo	D	I	1
20	Casa	1960	Adob.	Reg.	F	H	1
21	Quinta	1920	Adob.	Reg.	F	H	1
22	Quinta	1953-1940	Adob-Lad	Reg.	D	F-D	1
23	Quinta	1927-1944	Adob.	Reg.	F	G-F	1
25	Negocios,Taller	1982	C.A.	Bueno	B	D	1
30	Casa	1976	Lad.	Bueno	C	D	2
32	Quinta	1944	Lad.	Reg.	D	D	1
34	Casa	1939	Adob.	Reg.	F	H	1
35	Casa	1945	Adob.	Reg.	F	F	1
37	Casa	1953	Adob.	Reg.	F	F	1
38	Casa	1928	Adob.	Reg.	F	F	1
39	Casa	1928	Adob.	Reg.	F	F	1
41	Casa	1958	Adob.	Reg.	F	H	1
44	Quinta	1950	Adob.	Reg.	F	H	1

Manzana 42

Lote	Tipo(s) de Usos	Año(s) de Contrucc.	Material	Estado	Muros	Techo	Pisos
1	Casa, Quinta	1930,1952	Adob.	Reg.	F,F-D	H	1
2	Casa	1962	Adob.	Reg.	F	H	1
3	Casas	1997,1927	Lad,Adob	Bueno,reg	C,F	D,F	2,1
4	Quinta	1930	Adob.	Reg.	F	H	1
5	Casa	1930	Adob.	Malo	F	G	1
6	Quinta	1930	Adob.	Reg.	F	H	1
7	Casa	1990	Lad.	Muy Bueno	C	C	3
8	Casa	1940	Adob.	Reg.	F	G	1
9	Quinta	1950	Adob-Lad	Reg.	F-D	F-D	1
11	Quinta	1940	Lad.	Bueno	C	D	1
12	Quinta	1940	Adob.	Reg.	F-E	F-H	2
14	Quinta	1964	Lad.	Bueno.	D	D	1

Manzana 43

Lote	Tipo(s) de Usos	Año(s) de Contrucc.	Material	Estado	Muros	Techo	Pisos
1	Casa	1950	Adob.	Reg.	F	F	1
2	Casa	1929	Adob.	Reg.	F	F	1
3	Quinta	1931	Adob.	Reg.	F	H	1
4	Casa	1931	Adob.	Reg.	F	F	1
5	Casa	1931	Adob.	Reg.	F	H	1
6	Casa	1944	Adob.	Reg.	F	H	1
7	Casa	1950	Adob.	Malo	F	F	1
8	Casa	1950	Adob.	Malo	F	F	1
9	Casa	1935	Adob.	Reg.	F	H	1
12	Casa	1945	Adob.	Reg.	F	F	1
13	Casa	1940	Adob.	Reg.	F	H	1
14	Callejón	1940	Adob.	Malo	F	H	1
15	Quinta	1957	Adob-Lad.	Reg.	F-D	F-D	1
17	Callejón	1940	Adob.	Reg.	F	H	1
19	Quinta	1956-1938	Adob.	Reg.	F	H	1
20	Callejón	1940	Adob.	Reg.	F	F	1
21	Callejón	1942	Adob.	Reg.	F	H	1
22	Callejón	1945	Adob.	Reg.	F	G	1
23	Casa	1940	Adob.	Reg.	F	H	1
24	Cornedor	1980	Lad.	Bueno	C	D	1
26	Casa	1950	Adob.	Malo	F	H	1
27	Casa	1980	Lad.	Bueno	C	D	3
28	Casa	1950	Adob.	Reg.	F	H	1
31	Edificio	1963	Lad.	Reg.	C	D	1
32	Callejón	1950	Adob.	Reg.	F	H	1
33	Quinta	1950	Adob.	Malo	F	H	1
34	Callejón	1938	Adob.	Malo	F	H	1
35	Quinta	1933	Adob.	Reg.	F	F	1
38	Quinta	1943	Adob.	Reg.	F	H	1
39	Corralón	1962	Adob.	Reg.	F	G	1
40	Corralón	1962	Adob.	Malo	F	G	1
42	Callejón	1938	Adob.	Reg.	F	G	1
45	Quinta	1943	Adob.	Reg.	F	H	1
46	Quinta	1953-1981	Adob-Lad.	Reg.	F-C	H-D	1-3
47	Casa	1941	Adob.	Reg.	F	H	1

Manzana 44

Lote	Tipo(s) de Usos	Año(s) de Contrucc.	Material	Estado	Muros	Techo	Pisos
1	Casa Desocupada	1930	Adob.	Reg.	F	H	1
2	Quinta	1930-1943	Adob.-Lad.	Reg.Bueno	F-C	H-D	1
3	Callejón	1930	Adob.	Reg.	F	H	1
4	Casas	1925	Adob.	Reg.	F	H	1
5	Casa	1950	Adob.	Reg.	F	F	1
7	Casa	1938	Adob.	Reg.	F	H	1
8	Casa	1916	Adob.	Reg.	F	H	1
11	Casa	1943	Adob.	Reg.	F	H	1
12	Casa	1921	Adob.	Reg.	F	F	1
14	Taller	1940	Adob.	Malo	F	G	1
15	Edificio	1985	Lad.	Bueno	C	D	4
19	Casa	1960	Adob.	Reg.	F	H	1
20	Casa	1921	Adob.	Reg.	F	F	1
22	Casa	1907	Adob.	Reg.	F	G	1
23	Casa	1930	Adob.	Reg.	F	G	1

Manzana 45

Lote	Tipo(s) de Usos	Año(s) de Contrucc.	Material	Estado	Muros	Techo	Pisos
1	Casa	1937	Adob.	Reg.	F	H	1
3	Casa	1931	Adob.	Reg.	F	H	1
4	Casa	1930	Adob.	Reg.	F	H	1
5	Casa	1949	Adob.	Reg.	F	F	1
6	Casa	1939	Adob.	Bueno	F	F	1
8	Casa	1991	Lad.	Reg.	D	F	1
9	Casa	1971	Lad.	Bueno	C	D	1
11	Quinta	1930	Adob.	Reg-Malo	F	H	1
12	Callejón	1939-1927	Adob.	Malo-Reg	F	G-H	1
15	Quinta	1959	Lad.	Bueno	D	D	2
16	Casa	1930	Adob.	Reg.	F	H	1
17	Casa	1936	Adob.	Reg.	F	F	1
18	Quinta	1942	Adob.	Reg-Malo	F	H	1
19	Casa	1933	Adob.	Reg.	F	F	1
21	Lavandería	1962	Adob.	Reg.	F	H	1
23	Casa	1929	Adob.	Reg.	F	F	1
24	Casa	1930	Adob.	Reg.	F	G	1
26	Casa	1949	Lad.	Bueno	D	E	1
27	Quinta	1910	Adob.	Reg-Malo	F	H	1
29	Casa	1943	Adob.	Reg.	F	F	1
30	Quinta	1922-1919	Adob.	Reg-Malo	F	F-H	1

Manzana 47

Lote	Tipo(s) de Usos	Año(s) de Contrucc.	Material	Estado	Muros	Techo	Pisos
1	Edificio de Oficinas	1986	Lad.	Reg.	C	D	3
2	Quinta	1954-1984	Adob-Lad.	Reg-Bueno	F-C	H-D	1
3	Quinta	1961	Lad.	Reg.	C	D	2
4	Casa Desocupada	1911	Adob.	Malo	F	H	1
5	Quinta	1930	Adob.	Reg.	F	F-H	1
6	Colegio	1901,1992	Adob,Lad	Reg,Bueno	F,C	H,D	2
7	Casa	1962	Adob.	Reg.	F	H	1
8	Casa	1926	Adob.	Reg.	F	H	1
9	Casas	1930	Adob.	Reg.	F	H	1
11	Casa	1968	Adob.	Reg.	F	H	1
12	Casas	1931	Adob.	Reg.	F	F	1
13	Casa	1936	Adob.	Reg.	F	H	1
14	Casa	1932	Adob.	Reg.	F	H	1
15	Casa	1935	Adob.	Reg.	F	H	1
16	Vivienda Ferreteria	1962	Lad.	Reg.	C	D	1
17	Quinta	1930	Lad.	Reg.	C	D	1-2
18	Quinta	1930	Adob.	Reg.	F	H	1
19	Casas	1940,1977-1988	Adob,Lad.	Reg,Bueno	F,C	H,D	1,3
20	Quinta	1933	Adob.	Reg.	F	F	1
21	Casa	1935	Lad.	Bueno	C	D	3
22	Casa	1943	Lad.	Bueno	D	H	1
23	Casa	1970	Adob.	Malo	F	H	1
24	Casa	1974	Adob.	Malo	F	H	1

Manzana 50

Lote	Tipo(s) de Usos	Año(s) de Contrucc.	Material	Estado	Muros	Techo	Pisos
2	Casa	1972	Lad.	Bueno	C	D	3
3	Casas	1907-1927	Adob-Lad.	Reg-Bueno	F-D	F	1
4	Negocios	1962	Lad.	Reg-Bueno	C	H	1
5	Casa	1953	Adob.	Reg.	F	F	1
7	Casa	1933	Adob.	Reg.	F	H	1
8	Casa	1972	Lad.	Bueno	C	D	3
9	Tienda	1983	C.A.	Bueno	B	D	1
10	Casas	1937,1940,1930	Adob.	Reg.	F	H	1
12	Casa	1964	Adob.	Reg.	F	H	1
14	Casa	1945	Adob.	Bueno	F	F	1
15	Casas	1969-1955	Lad.	Bueno	C	D	1
16	Casas	1943-1973	Lad.	Bueno	C	D	1
17	Quinta	1919-1952	Adob.	Reg-Malo	F	F-G-H	1
21	Casa	1970	Lad.	Bueno	C	D	1
22	Casa	1919	Adob.	Reg.	F	F-H	2
23	Casas	1913	Adob.	Reg.	F	F	1

Manzana 51

Lote	Tipo(s) de Usos	Año(s) de Contrucc.	Material	Estado	Muros	Techo	Pisos
1	Casa	1904	Adob.	Reg-Malo	F	H-G	1
3	Quinta	1938	Adob.	Reg.	F	F	1
4	Casa	1930	Adob.	Reg.	F	F	1
6	Casas	1942	Adob.	Reg.	F	G	1
7	Casa	1945	Lad.	Bueno	C	E	1
8	Quinta	1938	Adob.	Reg.	F	H	1
9	Casas	1942	Adob.	Reg.	F	G	1
10	Tienda	1974	Lad.	Reg.	C	D	1
12	Casas	1927	Adob.	Reg.	F	G	1
13	Quinta	1953	Adob.	Reg.	F	F-G	1
14	Quinta	1929	Adob.	Reg.	F	H	1
16	Casa	1938	Adob.	Malo	F	H	1
17	Callejón	1924	Adob.	Malo	F	F	1
18	Solar	1957	Adob.	Reg-Malo	F-D	G-H	1
20	Quinta	1926	Adob.	Reg-Malo	F	G-H	1
21	Quinta	1958	Lad.	Bueno	D	D	1
22	Casa	1959	Adob.	Reg.	F	H	1
23	Casa	1925	Adob.	Reg.	F	H	1
24	Quinta	1917-1940	Adob.	Reg.	F	F-H	1
26	Quinta	1907	Adob.	Muy Malo	F	F	1
27	Casa	1940	Adob.	Reg.	F	F	1
29	Casa	1990,1940	Lad,Adob.	Bueno,Reg	C,F	D,H	2,1
31	Casas	1942	Adob.	Reg.	F	H	1
32	Quinta	1935	Adob.	Reg.	F	F-H	1
33	Casa	1958	Adob.	Reg.	F	F	1
34	Casa	1932	Adob.	Reg.	F	F	1

Manzana 52

Lote	Tipo(s) de Usos	Año(s) de Contrucc.	Material	Estado	Muros	Techo	Pisos
1	Resturant	1928	Adob.	Reg.	F	F	1
2	Lavanderia	1933	Adob.	Reg.	F	H	1
3	Casas	1920	Adob.	Malo	F	F	1
8	Casa	1930	Adob.	Malo	F	H	1
11	Casa	1968	Adob.	Reg.	F	G	1
12	Quinta	1935-1978	Lad.	Bueno-Reg	C-F	D-H-F	1
13	Casa	1972	Lad.	Bueno	C	D	1
14	Quinta	1933-1964	Adob.	Reg.	F	F	1
15	Casa	1934	Adob.	Bueno	F	F	1
16	Casa	1944	Adob.	Reg.	F	H	1
17	Casa	1949	Adob.	Reg.	F	F	1
18	Casa	1924	Adob.	Reg.	F	F	1
19	Colegio	1999,1935	Lad,Adob,Lad	Bueno, Reg	C,F	D,H	3,1
20	Casas	1936	Adob.	Reg.	F	F	1
21	Quinta	1957	Adob.	Reg.	F	F	1
22	Colegio	1940	Lad.	Reg.	C	D	1
23	Quinta	1920-1925	Adob-Lad	Reg.	F	F	1
24	Casas,Taller	1928,1939	Adob,Lad	Reg.	F,D	F,I	1
25	Quinta	1928	Adob.	Reg.	F	H-F	1
28	Casa	1946	Adob.	Bueno	F	F	1
29	Casa	1932	Adob.	Malo	F	F	1
31	Edificio Vivienda	1988	C.A.	Muy Bueno	B	D	3
33	Casa	1980	Lad	Malo	C	H	1
36	Casa	1950	Adob.	Malo	F	F	1
37	Casas	1987	Lad.	Bueno	C	D	1
40	Casa	1953	Lad.	Reg.	C	D	1

Manzana 53

Lote	Tipo(s) de Usos	Año(s) de Contrucc.	Material	Estado	Muros	Techo	Pisos
1	Quinta	1994-1996	Lad.	Bueno	C	D	1
2	Casa	1930	Adob.	Reg.	F	H	1
3	Casas	1959-1949	Lad.	Bueno	D	D	1
5	Casa	1930	Lad.	Bueno	C	D	1
6	Casa	1934	Adob.	Reg.	F	H	1
7	Quinta	1930	Adob.	Reg.	F	F	1
9	Quinta	1958	Adob.	Reg.	F	H	1
10	Quinta	1930	Adob.	Reg-Malo	F	H	1
11	Quinta	1959	Adob.	Reg.	F	H	1
12	Quinta	1930	Adob.	Reg.	F	H	1
13	Quinta	1930	Adob.	Reg.	F	H	1
14	Casas	1950-1955	Lad.	Bueno	C	D	1
15	Fábrica	1930	Adob.	Reg.	F	H	1
17	Quinta	1933	Adob.	Reg.	F	G	1
18	Casa	1987	Lad.	Muy Bueno	C	D	3
19	Casa	1940	Lad.	Reg.	C	D	1
21	Casa	1930	Adob.	Reg.	F	H	1

Manzana 54

Lote	Tipo(s) de Usos	Año(s) de Contrucc.	Material	Estado	Muros	Techo	Pisos
1	Conjunto Habitacional	1988	C.A	Bueno	B	D	5
2	Edificio de Viviendas	1963	Lad.	Bueno	C	D	2

Manzana 55

Lote	Tipo(s) de Usos	Año(s) de Contrucc.	Material	Estado	Muros	Techo	Pisos
1	Casa	1943	Adob.	Reg.	F	G	1
2	Casa	1960	Adob.	Reg.	F	H	1
3	Casa	1947	Adob.	Reg.	F	H	1
4	Casa	1943	Adob.	Reg.	F	G	1
5	Casa	1970	Adob.	Reg.	F	H	1
6	Depósito	1960	Adob.	Reg.	F	H	1
8	Callejón	1948	Adob.	Reg.	F-D	H	1
9	Callejón	1949-1978	Lad-Adob.	Reg-Malo	F-D	H	1
12	Casas	1952	Adob.	Reg.	F	H	1
13	Casas	1954	Lad.	Reg.	C	D	1
14	Quinta	1968	Adob.	Reg.	F	H	1
15	Casa	1946	Lad.	Reg.	D	D	1
16	Casa	1992(1), 1994(2,3)	Lad.	Reg.	C	D	3
17	Casa	1985	Lad.	Muy Bueno	C	D	2
18	Casa	1989	Adob.	Reg.	F	F	1
19	Quinta	1945-1960	Lad-Adob.	Reg.	C-F	D-H	1
20	Quinta	1944-1973	Lad-Adob.	Reg.	C-F	D-G	1
21	Casa	1950	Lad.	Reg.	C	D	1
23	Unidad Especial	1943	Adob.	Reg.	F-G	H	1
24	Casa	1960	Adob.	Reg.	F	H	1

Manzana 56

Lote	Tipo(s) de Usos	Año(s) de Contrucc.	Material	Estado	Muros	Techo	Pisos
1	Negocio	1935	Adob.	Reg.	F	H	1
2	Restaurant	1947	Adob.	Reg.	F	H	1
4	Quinta	1945	Adob.	Reg.	F	F-H	1
5	Quinta	1946	Adob.	Reg.	F	F-H	1
6	Quinta	1960	Adob.	Reg.	F	F-H	1
7	Casas	1957	Lad.	Bueno	C	D	3
9	Casas	1946	Lad.	Bueno	D	D	1
12	Corralón	1948	Adob.	Malo	F	F-H	1
13	Casa	1949	Adob.	Malo	F	F-H	1
14	Casa	1960	Adob.	Reg.	F	H	1
15	Casa	1929	Adob.	Reg.	F	H	1
16	Quinta	1966	Lad.	Bueno	C	D	3
17	Quinta	1966	Lad.	Bueno	C	D	3
18	Quinta	1966	Lad.	Bueno	C	D	3
19	Casa	1948	Adob.	Reg.	F	F	1
20	Casa	1965	Adob.	Reg.	F	H	1
21	Quinta	1955	Adob.	Reg.	F	F	1
22	Casa	1945	Adob.	Reg.	F	H	1
23	Casa	1965	Adob.	Reg.	F	F	1
25	Casa	1910	Adob.	Reg.	F	F	1
26	Casa	1965	Adob.	Reg.	F	F	1

Manzana 57

Lote	Tipo(s) de Usos	Año(s) de Contrucc.	Material	Estado	Muros	Techo	Pisos
1	Tiendas	1935	Adob.	Reg.	F	H	1
2	Tiendas, Depósitos	1960,1975	Adob,Lad	Bueno	F,C	H-G,D	1
3	Industria	1979	Lad.	Bueno	D	G	1
4	Manufacturas	1979	Lad.	Bueno	D	G	1
7	Industria	1930	Adob.	Reg.	F	H	1
8	Casa	1971	Lad.	Reg.	C	D	3
9	Casa	1971	Lad.	Reg.	C	D	2
10	Industria	1980	Lad.	Bueno	C	E	1
11	Tienda	1927	Adob.	Reg.	F	H	1
12	Comedor	1942	Adob.	Reg.	F	H	1
13	Imprenta	1940	Adob.	Bueno	F	H	1
15	Casas	1930,1925	Lad,Adob	Reg,Bueno	D,F	G,F	1

Manzana 58

Lote	Tipo(s) de Usos	Año(s) de Contrucc.	Material	Estado	Muros	Techo	Pisos
1	Casa	1970	Adob.	Reg.	F	H	1
2	Quinta	1960-1965	Lad.	Reg.	C-D	D-G	3-2
3	Quinta	1947-1989	Lad.	Bueno-Reg.	D-C	H-D	1-3-4
4	Casa	1979	Lad.	Reg.	C-F	D-G	1
5	Quinta	1950	Adob.	Reg.	F	H	1
6	Quinta	1961-1965	Lad.	Reg.	C	D	1
7	Corralón	1933	Adob.	Malo	F	H-G	1
9	Casas	1976	Adob.	Reg.	F	H	1
10	Casas	1989	Lad.	Reg.	C	D	2
11	Casas	1974,1992	Lad.	Reg.	C	D	2
12	Casas	1949	Adob.	Reg.	F	F	1
13	Callejón,Quinta	1958,1959	Adob.	Reg.	F	G	1
14	Callejón	1974	Adob.	Malo	F	H	1
15	Quinta	1985	Lad.	Reg.	C	D	3
16	Quinta	1983	Lad.	Reg.	C	D	3
17	Casa	1989	Lad.	Bueno	C	D	2
19	Casa	1952	Adob.	Malo	F	G	1
20	Corralón	1971	Adob.	Reg.	D	F	1
21	Casas	1970,1979	Lad.	Reg.	D,C	D,H	1
25	Quinta,Casa,Iglesia	1929,1990,1986	Adob.,Lad,Lad	Reg,Reg,B	F,C,D	F,D,D	1,3,2

Manzana 59

Lote	Tipo(s) de Usos	Año(s) de Contrucc.	Material	Estado	Muros	Techo	Pisos
1	Callejón	1970	Adob.	Reg.	F	H-G	1-2
3	Casa	1965	Lad.	Bueno	D	D	3
4	Casa	1965	Lad.	Bueno	C	D	3
5	Casa	1967	Lad.	Reg.	D	D	3
6	Casa	1965	Lad.	Reg.	C	D	3
7	Casa	1965	Lad.	Reg.	C	D	2
8	Casa	1967	Lad.	Reg.	C	D	2
9	Casa	1967	Lad.	Reg.	C	D	2
10	Casa	1936	Adob.	Malo	F	H	1
11	Carpintería	1936	Lad,Adob.	Reg.	C,E	D,H	1
12	Casas	1929,1960	Adob,Lad.	Reg,Bueno	F,C	H,D	1,2
14	Casas	1914,1996	Adob,Lad.	Reg,Bueno	F,C	F,D	1
16	Casas	1920,1932	Adob;Lad	Reg.	F,D	H,F	1,3
18	Casa	1920	Adob.	Reg.	F	H	1
19	Tienda	1912,1919	Adob,Lad.	Reg,Bueno	F,C	F,D	1
20	Quinta	1923-1977	Adob.	Reg-Malo	F	H-F	1-3

Manzana 60

Lote	Tipo(s) de Usos	Año(s) de Contrucc.	Material	Estado	Muros	Techo	Pisos
1	Casa	1896	Adob.	Reg.	F	F	2
2	Casa	1917	Lad.	Bueno	C	D	1
3	Casas	1948,1943,1955	Adob,Lad	Reg,Bueno	F,C	F,D,F	1,3,2
4	Casa	1946	Adob.	Reg.	F	F	1
5	Prop. Horizontal	1940	Adob.	Reg.	F	F	1
6	Quinta	1919-1945,1970	Adob,Lad	Reg, Bueno	F-H,C	F-H,F	1
7	Casa	1929	Adob.	Reg.	F	F	1
9	Casa	1958	Adob.	Reg.	F	F	1
11	Casa	1974	Lad.	Reg.	C	D	2
12	Casa	1970	Lad.	Reg.	C	D	3
13	Casa	1972	Lad.	Reg.	C	D	3
14	Casa	1975	Lad.	Reg.	C	D	3
15	Casa	1975	Lad.	Reg.	C	D	3
16	Casa	1975	Lad.	Reg.	C	D	3
17	Casa	1975	Lad.	Reg.	C	D	3
18	Casa	1975	Lad.	Reg.	C	D	3
19	Casa	1975	Lad.	Reg.	C	D	3
20	Casa	1975	Lad.	Reg.	C	D	3
21	Casa	1975	Lad.	Reg.	C	D	3
22	Casas	1971	Lad.	Reg.	C	D	3
23	Casa	1975	Lad.	Reg.	C	D	3
24	Casas	1969	Lad.	Bueno	C	D	3
25	Casas	1981	Lad.	Bueno	C	D	3,1
26	Casas	1982	Lad.	Bueno	C	D	3
27	Casa	1973	Lad.	Bueno	C	D	2
28	Casa	1973	Lad.	Bueno	C	D	2
29	Casa	1970	Lad.	Bueno	C	D	3
30	Casa	1975	Lad.	Bueno	C	D	3
31	Casa	1989	Lad.	Bueno	C	D	3
32	Casa	1989	Lad.	Bueno	C	D	3
33	Casa	1989	Lad.	Reg.	C	D	3
34	Casa	1989	Lad.	Bueno	C	D	3
35	Casa	1989	Lad.	Bueno	C	D	3
36	Casa	1969	Lad.	Bueno	C	D	2
37	Casa	1965,1985	Lad.	Bueno	C	D	2
38	Casa	1958	Adob.	Reg.	F	F	1
39	Casa	1944	Adob.	Reg.	F	H	1
40	Casa	1944	Adob.	Reg.	F	F	1
41	Quinta	1970-1980	Lad.	Bueno	C	D	2y3
46	Casas	1900	Adob.	Reg-Malo	F	G-H	1
47	Casa	1928	Adob.	Malo	F	F	1
52	Casa	1985	Lad.	Bueno	C	D	2
53	Casa	1958	Adob.	Malo	F	H	1
55	Casa	1951	Adob.	Malo	F	H	1
56	Casa	1955	Adob.	Reg.	F	H	1
57	Casa	1955	Adob.	Malo	F	H	1
58	Casa	1955	Adob.	Reg.	F	F	1
59	Casa	1955	Adob.	Reg.	F	F	1
61	Casa	1941	Adob.	Muy Malo	F	H	1
62	Casa	1950	Adob.	Reg.	F	H	1
63	Casa	1958	Adob.	Reg.	F	H	1
64	Casa	1951	Adob.	Malo	F	H	1
65	Casa	1958	Lad.	Muy Malo	C	D	1
69	Casas	1964	Adob.	Reg.	F	F	1

Manzana 61

Lote	Tipo(s) de Usos	Año(s) de Contrucc.	Material	Estado	Muros	Techo	Pisos
1	Edificio	1982	C.A.	Buen-Reg	B	D	5
3	Edificio	1968	Lad.	Reg.	- C	D	3
4	Quinta	1965-1970	Adob-Lad	Reg-Buena	F-C	H-D	1
5	Casa	1965	Lad.	Reg.	C	D	3
7	Quinta	1954	Adob.	Malo	F-C	H-D	1
8	Casa	1954	Lad.	Reg	D	D	1
9	Quinta	1939	Adob.	Reg.	F-C	F-H	1
10	Casa	1975	Lad.	Buena	C	D	2
11	Casa	1962	Lad.	Reg.	C	D	1
12	Casa	1962	Lad.	Reg.	C	D	3
13	Casa	1962	Lad.	Reg.	C	D	1
14	Tienda Desocupada	1972	Adob.	Malo	F	H	1
16	Casa	1968	Lad.	Reg.	C	D	1
18	Quinta	1940-1945,1984	Adob,Lad	Reg-Malo,B	F,C	H,D	1,3
19	Casas	1947	Adob.	Reg.	E,F	F,G	1
20	Casa	1958	Lad.	Reg.	C	D	1
21	Farmacia,Comercio	1958	Lad.	Buena,Reg	C	D	1
22	Estac.,Depósito,Coleg	1953	Lad.	Reg.	D,C,F	G,H,H	1
24	Quinta	1936-1953	Adob.	Reg-Malo	F	H	1

Manzana 62

Lote	Tipo(s) de Usos	Año(s) de Contrucc.	Material	Estado	Muros	Techo	Pisos
1	Casas	1952	Lad.	Reg.	D	D	1
2	Casa	1956	Lad.	Reg.	C	D	3
3	Quinta	1940-1951	Adob.	Reg.	F-D	H-D	1
4	Quinta	1940	Lad.	Reg.	D	D	2
5	Casas	1948	Adob.	Reg.	F	H	1
6	Casas	1955	Adob.	Reg.	F	H	1
7	Almacen	1953	Lad.	Reg.	D	E	1
10	Casa	1966	Lad.	Reg-Buena	C	D	3
11	Casa	1965	Lad.	Reg.	C	D	1
12	Casa	1965	Lad.	Reg.	C	D	1
13	Casas	1967,1987	Lad.	Reg.	D,C	D,G	1
14	Casa	1964	Lad.	Reg.	C	D	1
15	Casa	1967	Lad.	Buena	C	D	2
17	Casa	1967	Lad.	Buena	C	D	3
19	Quinta	1974-1976	Lad.	Buena	C	D	3
20	Casa	1975	Lad.	Reg.	C	D	1
21	Quinta	1962	Lad.	Reg.	D	E	2
22	Casa	1963	Lad.	Reg.	C	E	1
23	Casa	1950	Adob.	Reg.	F	H	1
24	Quinta	1946-1982	Adob.	Reg.	F	H	1

Sector 3

Manzana 4

Lote	Tipo de Usos	Año(s) de Contrucc.	Material	Estado	Muros	Techo	Pisos
1	Casa	1935	Lad.	Reg.	C	D	1
2	Casa	1987	Lad.	Reg.	C	D	1
3	Casa	1901	Lad.	Reg.	C,C,D	F	3
4	Edificio	1992	C.A.	Bueno	B	D	12
5	Edificio	1984	C.A.	Bueno	B	D	5
6	Casas	1938-1940	Adob.	Reg.	F	F-H	2-1
7	Casas	1952	Lad.	Reg.	C	D	1-2

Manzana 6

Lote	Tipo de Usos	Año(s) de Contrucc.	Material	Estado	Muros	Techo	Pisos
1	Edificio de Viv.	1960	C.A.	Bueno	B	D	5
2	Casa	1935	Lad.	Reg.	C	D	2
3	Casas	1937-1972	Adob-Lad	Reg.	F-C	F-D	2
4	Casa	1949,1986	Lad.	Reg.	C	D	2
5	Casa	1914	Adob.	Bueno	F	F	2
6	Casa	1978	Adob.	Reg.	F	F	1
7	Casa	1975	Lad.	Reg.	C	D	2
8	Edificio de Viv.	1992	C.A.	Muy Bueno	B	D	3
10	Edificio de Viv.	1985	C.A.	Muy Bueno	B	D	6

Manzana 8

Lote	Tipo de Usos	Año(s) de Contrucc.	Material	Estado	Muros	Techo	Pisos
1	Embajada de España	1900	Lad.	Muy Bueno	D	D	3
2	Quinta	1961	Lad.	Reg.	C	D	2-3
3	Casa	1968,1967	Lad.	Bueno	C	D	3
4	Casas	1958-1987	Lad.	Bueno	C	D	3
5	Agencia	1963	Lad.	Bueno	C	D	1
6	Casa	1931	Adob.	Reg.	F	F	1
7	Edificio	1982	C.A.	Bueno	B	D	2
8	Edificio	1971	C.A.	Bueno	B	D	3
9	Colegio	1927,1968,1999	Adob,C.A	Mal,Bueno	F,B	D,D	2,3

Manzana 9

Lote	Tipo de Usos	Año(s) de Contrucc.	Material	Estado	Muros	Techo	Pisos
1	Casas	1959	Lad.	Bueno	D	D	1
2	Quinta,Casas	1915-1918	Adob.	Reg.	F	H,F	1
3	Estacionamiento	1984	Lad.	Reg.	C	D	1
4	Desocupado	1956	Lad.	Reg.	C	D	3
5	Quinta	1920	Adob.	Bueno-Reg.	F	F	1
6	Casas	1936-1938	Lad.	Bueno	D	F	1
7	Casa	1945	Adob.	Reg.	F	F	1
9	Casas, Panad.,Juegos	1958,1942,1942	Lad.	Reg.	C,C,D	D	2-3,1,1
11	Casa	1979,1996	Adob,Lad.	Reg,Bueno	F,D	F,D	2
12	Casas	1951-1998,1967-1973	Lad.	Bueno	C,D	D	3,2
13	Casa	1961	Lad.	Bueno	D	D	1
14	Iglesia	1980	C.A,Lad.	Bueno	B,C	D	2
15	Casa	1950	Adob.	Reg.	F	F	1
16	Quinta	1952	Lad.	Reg.	D	D	1-2
17	Casas,Bodega	1930-1943,1920	Adob.	Reg.	F	F	1
18	Casas	1940-1970,1944	Lad,Adob.	Reg.	C,F	D,F	1-2,1

Manzana 11

Lote	Tipo de Usos	Año(s) de Contrucc.	Material	Estado	Muros	Techo	Pisos
1	Casa	1939	Adob.	Reg.	F	F	2
3	Casa	1977	Lad.	Bueno	C	D	2
4	Casa	1972	Lad.	Bueno	C	D	3
5	Casa	1980	Lad.	Reg.	D	D	3
6	Edificio	1979	C.A.	Muy Bueno	B	D	4
7	Casa	1980	Lad.	Bueno	C	D	1
8	Casa	1969	Lad.	Reg.	C	D	2
9	Casas	1942	Adob.	Reg.	F	F-H	1
10	Quinta	1965	Adob.	Reg.	F	F	1
12	Casa	1988	Lad.	Bueno	C	D	3
13	Casa	1955	Adob.	Reg.	F	F	1
14	Casa	1933	Adob.	Reg.	F	F	1
16	Casa	1951	Adob.	Reg.	F	H	1
17	Casa	1991	Lad.	Reg.	C	D	3
18	Casa	1971	Lad.	Reg.	C	D	3
20	Quinta	1944	Adob.	Reg.	F	H	1

Manzana 13

Lote	Tipo de Usos	Año(s) de Contrucc.	Material	Estado	Muros	Techo	Pisos
1	Casas	1968	Lad.	Bueno	C	D	3
2	Consultorio	1974	Lad.	Bueno	C	D	2
3	Casa	1960	Lad.	Bueno	C	D	2
4	Casa	1962	Lad.	Bueno	C	D	3
5	Casa	1965	Lad.	Reg.	C	D	3
6	Casa	1961	Lad.	Bueno	C	D	3
7	Casa	1960	Lad.	Reg.	C	D	2
8	Negocio	1978	Lad.	Bueno	C	D	2
9	Casa	1974	Lad.	Reg.	C	D	3
10	Casa	1968	Lad.	Bueno	C	D	3
11	Tienda	1970	Lad.	Bueno	C	D	3
12	Casa	1962	Lad.	Bueno	C	D	2
13	Casa	1960	Lad.	Bueno	C	D	3
14	Negocio	1964	Lad.	Bueno	C	D	2
15	Casa	1975	Lad.	Bueno	C	D	3
16	Casa	1970	Lad.	Bueno	C	D	3

Manzana 15

Lote	Tipo de Usos	Año(s) de Contrucc.	Material	Estado	Muros	Techo	Pisos
1	Casa	1964	Adob.	Reg.	F	F	1
2	Casa	1977	Lad.	Reg.	C	D	2
3	Casa	1950	Adob.	Reg.	F	E	1
4	Casa	1949	Adob.	Reg.	F	F	1
5	Casa	1915	Adob.	Reg.	F	F	1
6	Casa	1972	Lad.	Bueno	C	D	3
7	Casas	1963, 1996	Lad.	Reg. Bueno	C	D	1,3
8	Casa	1982	Lad.	Bueno	C	D	1
9	Casa	1912	Adob.	Reg.	F	G	1
10	Casa	1946	Adob.	Reg.	F	F	1
11	Quinta	1931	Adob.	Reg.	F	F	1
13	Casas	1992	Lad.	Reg.	C	D	1-2
15	Casa	1915	Adob.	Reg.	F	F	1
16	Casa	1916	Adob.	Reg.	F	F	1

Manzana 19

Lote	Tipo de Usos	Año(s) de Contrucc.	Material	Estado	Muros	Techo	Pisos
1	Estudio de Filmación	1914	Adob.	Bueno	F	H	2
2	Edificio	1998	C.A.	Muy Bueno	B	D	4
3	Casa	1978	Lad.	Bueno	C	D	3
4	Casa	1978	Lad.	Bueno	C	D	3
5	Estudio	1986	Lad.	Bueno	C	D	1

Manzana 20

Lote	Tipo de Usos	Año(s) de Contrucc.	Material	Estado	Muros	Techo	Pisos
1	Centro Recreación	1953	Adob,Lad.	Reg.	D,F	D,F	2
2	Mutual	1980	C.A.	Bueno	B	D	6
3	Comunid.Religiosa	1927	Adob.	Reg.	F	F	2
4	Casa	1920	Adob.	Reg-Malo	F	F	2
5	Casa	1938	Adob.	Reg.	F	F	1
6	Casa	1900	Adob.	Bueno	F	F	3
7	Casas	1955	Lad.	Reg.	C	D	3
8	Casas	1963	Lad.	Bueno	C-D	D	3
9	Casa	1962,1987,1990	Lad.	Bueno	C	D,C,D	3
11	Casa	1930	Lad.	Reg.	D	D	1
12	Casa	1923	Adob.	Bueno	F	F	2
13	Casa	1917	Adob.	Bueno	F	F	2
14	Casa	1970,1995	Lad.	Bueno	C,D	D,G	2
15	Casas	1984,1976,1985	Lad.	Bueno	C	D-F	3
16	Quinta	1973	Lad.	Bueno	C	D	1-3

Manzana 21

Lote	Tipo de Usos	Año(s) de Contrucc.	Material	Estado	Muros	Techo	Pisos
1	Casas	1936	Adob	Bueno	F	F	3,2
2	Casa	1999	Lad.	Muy Bueno	C	D	2
3	Casas	1921,1998	Adob,Lad.	Reg,Bueno	F,C	F,D	1,3
4	Edificio	1999	C.A.	Muy Bueno	B	D	5
5	Casa	1940	Adob	Bueno	F	F	2
7	Negocio	1928	Lad.	Bueno	C	D	2
8	Botica	1932	Lad.	Bueno	C	D	1
9	Quinta	1919-1989	Adob-Lad.	Reg.	F-D	F-D	1-2
10	Casa	1918	Adob	Bueno	F	F	1
12	Salón de Recep.	1942	Adob	Bueno	F	F	1
13	Restaurante	1942	Adob	Reg.	F	F	2
14	Casa	1912	Adob	Reg.	F	F	2
15	Centro de Salud	1983	Lad.	Reg.	C	D	2
17	Quinta	1960	Lad.	Reg.	C	D	2-3
18	Edificio	1953	C.A.	Muy Bueno	B	D	1
19	Casa	1912	Adob	Bueno	F	F	1
20	Casa	1946	Lad.	Bueno	C	D	2
22	Casa	1944	Lad.	Reg.	C	D	1
23	Casa	1951	Adob	Bueno	F	F	1

Manzana 23

Lote	Tipo de Usos	Año(s) de Contrucc.	Material	Estado	Muros	Techo	Pisos
1	Almacen	1930	Adob.	Reg.	F	F	1
2	Casa	1901	Adob.	Reg.	F	F	2
3	Casa	1939	Lad.	Reg.	C	D	3
4	Casa	1950	Adob.	Reg.	F	G	1
5	Casa	1950	Adob.	Reg.	F	G	1
6	Casa	1918	Adob.	Reg.	F	H	1
7	Casa	1934	Adob.	Reg.	F	F	1
8	Callejón	1950	Adob.	Malo	F	F-H-G	1
9	Casa	1994	Adob.	Reg.	E	H	1
10	Casas	1967	Lad-Adob	Reg.	C-F	D-H	1
11	Quinta	1951	Lad-Adob	Reg.	D-F	D-F-H	2-3
12	Casa	1932	Adob.	Reg.	F	H	1
13	Edificio de Viv.	1992	Lad.	Bueno	C	D	5
14	Casa	1959	Adob.	Reg.	F	H	2
15	Casa	1942	Adob.	Reg.	F	F	1
16	Edificio de Viv.	1974	Lad.	Bueno	C	D	5
19	Casa	1925	Adob.	Reg.	F	F	1
20	Casa	1927	Adob.	Reg.	F	F	1
21	Casa	1917	Adob.	Reg.	F	F	1
22	Casa	1930	Adob.	Reg.	F	F	1
23	Quinta	1925	Adob.	Reg.	F	F	1
24	Quinta	1931	Adob.	Reg.	F	F	1
25	Casa	1926	Adob.	Reg.	F	F	1
26	Casa	1927	Lad.	Reg.	C	D	1
27	Casa	1950	Lad.	Reg.	D	D	3
28	Casa	1918	Adob.	Reg.	F	F	2

Manzana 24

Lote	Tipo de Usos	Año(s) de Contrucc.	Material	Estado	Muros	Techo	Pisos
1	Casas	1924,1994	Adob-Lad.	Reg-Bueno	F,C	F,D	1,4
2	Colegio	1940,1980	Adob-Lad.	Reg.	F,C	F,D	2
3	Casa	1978	Lad.	Bueno	C	D	4
4	Casa	1975	Lad.	Reg.	C	D	3
5	Casa	1976	Adob	Reg.	F	F	1
6	Casa	1976	Adob	Reg.	F	F	1
9	Casas	1952-1992	Lad.	Reg.	C	D	2
10	Quinta	1930	Adob	Reg.	F	F	1
11	Colegio	1970	Lad.	Reg.	C	D	2
12	Casa	1973	Lad.	Reg.	C	D	2
14	Casa	1900	Adob	Reg.	F	F	1
17	Casa	1973	Lad.	Bueno	C	D	1
20	Casas	1984	Lad.	Reg.	C	D	2
21	Casas	1971	Lad.	Reg.	C	D	2
23	Casa	1970	Adob	Reg.	F	F	1
25	Casa	1919	Adob	Reg.	F	F	1
26	Casa	1930	Adob	Reg.	F	F	1
27	Mueblería	1930	Adob	Reg.	F	F	1
28	Centro Ocupacional	1950	Adob	Reg.	F	F	1
29	Casas	1951	Lad.	Reg.	C	D	2
32	Casa	1926	Adob	Reg.	F	F	1
33	Casa	1926	Adob	Reg.	F	F	1
34	Casa	1926	Adob	Reg.	F	F	1

Manzana 25

Lote	Tipo de Usos	Año(s) de Contrucc.	Material	Estado	Muros	Techo	Pisos
1	Casa	1921	Adob.	Reg.	F	F	2
2	Casa	1972	Lad.	Bueno	C	D	3
3	Casas	1981	lad.	Bueno	C	D,C	2
4	Casa	1969	Lad.	Bueno	C	D	2
5	Casa	1960	Lad.	Bueno	C	D	2
6	Casa	1947	Lad.	Bueno	C	D	1
7	Casas	1923	Adob.	Reg-Malo	F	F	1
8	Casas	1932	Adob.	Malo	F	F	2
9	Colegio	1914,1980,1999	Adob,Lad,Lad.	Reg.	F,C,C	H,D,D	3
10	Edificio de Viv.	1977	C.A.	Bueno	B	D	4
11	Edificio de Viv.	1970	C.A.	Bueno	B	D	4
13	Casas	1919	Adob.	Malo	F	F	1
14	Edificio de Viv.	1986	C.A.	Bueno	B	D	5
15	Quinta	1919	Adob.	Malo	F	F	2
16	Casas	1932,1999	Adob,Lad	Malo,Bueno	F,C	F,D	2,2
17	Gararge	1913	Adob.	Muy Malo	F	H	1
18	Casa	1923	Adob.	Malo	F	H	1
19	Edificio de Viv.	1985	C.A.	Bueno	B	D	3
20	Casa	1959	Lad.	Bueno	C	D	3
21	Casas	1938-1975	Lad.	Bueno	C	D	2
22	Casa, Teatro	1919,1920	Adob.	Malo	F	F	1
23	Casa	1927	Adob.	Malo	F	F	1
24	Casa	1960	Lad.	Bueno	C	D	3

Manzana 27

Lote	Tipo de Usos	Año(s) de Contrucc.	Material	Estado	Muros	Techo	Pisos
1	Casa	1930	Adob.	Reg.	F	F	1
2	Casa	1930	Adob.	Reg.	F	F	1
3	Casa	1948	Adob.	Reg.	F	F	1
4	Casa	1910	Adob.	Reg.	F	H	1
5	Casa	1913	Adob.	Reg.	F	F	2
6	Colegio	1933,1984,1999	Adob,C.A., Lad	Reg,Bue,Bue.	F,B,C	F,D,I	1,3,1
7	Casa	1933	Adob.	Reg.	F	F	1
8	Casa	1900	Adob.	Reg.	F	F	2
9	Colegio,Casas	1904	Adob.	Reg.	F	F	2
10	Estacionamiento	1900	Adob.	Reg.	F	F	1
11	Quinta	1951	Lad.	Bueno	C-D	C-D	1-3
12	Casa	1968	Lad.	Bueno	C	D	2
13	Casa,Negocio	1900,1920	Adob.	Reg.	F	F	1
14	Edificio Comerc.	1980	C.A.	Bueno	B	D	5
15	Casa	1920	Adob.	Reg.	F	H	1
16	Comercio	1943	Adob.	Reg.	F	H,F,F	3
17	Quinta	1940	Adob.	Reg.	F	F	1

Manzana 29

Lote	Tipo de Usos	Año(s) de Contrucc.	Material	Estado	Muros	Techo	Pisos
1	Casas	1993-1998	Lad.	Bueno	C	D	2-3
3	Casas	1933	Lad.	Bueno-Reg.	C	D	2,1
4	Casas	1919-1947	Adob	Reg-Malo	F,E	F,G	1,2
5	Casas	1927	Adob	Reg.	F	F	1
6	Casas	1927	Adob	Reg.	-F	F	1
7	Casa,Galeria	1919	Adob	Bueno	F	F	1
8	Casa	1952	Adob	Bueno	F	F	1
10	Casas	1987,1990	Lad,Adob	Bueno-Reg	C,F	D,F	3,1
11	Comercio,Casa	1913	Adob	Reg	F	F	1
12	Casa	1910	Adob	Reg.	F	F	2
13	Casa	1914	Adob	Reg.	F	F	1
14	Casa	1914	Adob	Reg.	F	F	1

Manzana 31

Lote	Tipo de Usos	Año(s) de Contrucc.	Material	Estado	Muros	Techo	Pisos
3	Casa	1981	C.A.	Bueno	B	D	3
5	Casas	1983	C.A.	Bueno	B	D	2,2,3
6	Edificio de Viv.	1997	C.A.	Muy Bueno	B	D	10
7	Casas	1956,1997,1988	Lad.	Bueno	C	D	3
9	Casa	1981,1990	C.A(1,2),Lad(3)	Reg.	B,B,C	D,D,F	3
10	Quinta	1978	Lad.	Bueno	C	D	2-3
11	Casa	1965	C.A.	Bueno	B	D	1
13	Casa	1975	Lad.	Bueno	C	D	2
15	Casa	1933	Lad.	Bueno	C	D	2

Manzana 34

Lote	Tipo de Usos	Año(s) de Contrucc.	Material	Estado	Muros	Techo	Pisos
1	Casa Desocupada	1920	Adob.	Reg-Bueno	F	H	1
2	Casa Desocupada	1924	Adob.	Reg.	F	F	2
3	Banco	1950	C.A.	Muy Bueno	B	D	4
4	Ferretería	1996	C.A.	Muy Bueno	B	D	2
5	Casa	1958	Adob.	Bueno	F	F	2
6	Tienda,Casa	1948,1929	Adob.	Reg.	F	F	2,1
7	Casa	1964	Adob.	Bueno	F	F	1
8	Casas	1966	Lad.	Bueno	D	F	1

Manzana 35

Lote	Tipo de Usos	Año(s) de Contrucc.	Material	Estado	Muros	Techo	Pisos
1	Negocio,Mercado	1942	Adob-Lad.	Reg.	F-D-E	F-I-H	1

Manzana 38

Lote	Tipo de Usos	Año(s) de Contrucc.	Material	Estado	Muros	Techo	Pisos
1	Agencia,Casas	1930,1997	Adob,Lad.	Reg,Buena	F,C	H,D	1,2
2	Estudio de Grabac.	1900	Adob	Buena	F	F	1
3	Edificio	1973	C.A.	Buena	B	D	4
4	Casa	1975	Lad.	Buena	C	D	3
5	Casa	1975	Lad.	Buena	C	D	3
6	Casa	1975	Lad.	Buena	C	D	3
7	Quinta	1975	Lad.	Buena	C	D	3-2
8	Casa	1975	Lad.	Buena	C	D	3
9	Casa	1976	Lad.	Buena	C	D	3
10	Casa	1976	Lad.	Buena	C	D	3
11	Casa	1975	Lad.	Buena	C	D	3
12	Casa	1976	Lad.	Buena	C	D	2
13	Edificio	1976	Lad.	Buena	C	D	4
14	Casa	1975	Lad.	Buena	C	D	3
15	Casa	1982	Lad.	Buena	C	D	3
16	Galerías	1999	Lad.	Buena	C	D	1
17	Casa Desocupada	1905	Adob	Reg.	E	F	1
18	Estacionamiento	1988	Adob	Reg.	F	F	1
19	Banco	1979	C.A.	Muy Buena	B	D	3
20	Banco	1977	C.A.	Muy Buena	B	D	1
21	Edificio de Viv.	1974	C.A.	Reg.	C	D	1
22	Casas	1924	Adob	Reg.	F	F	2
23	Casas	1917	Adob	Reg.	F	F	1
24	Quinta	1934-1944	Adob	Reg.	F	F	1-2
25	Casas,Negocio	1944	Adob	Reg.	F	F	2

Manzana 39

Lote	Tipo de Usos	Año(s) de Contrucc.	Material	Estado	Muros	Techo	Pisos
1	Casa	1902	Adob.	Reg.	F	F	1
2	Casa	1943	Adob.	Buena	F	F	3
3	Casa	1918	Adob.	Buena	F	F	2
4	Casas	1916	Adob.	Buena	F	F	1
5	Casas	1931	Adob-Lad.	Reg-Buena	F-D	F	1
6	Casa	1947	Adob.	Reg.	F	H	1
7	Quinta	1930-1980	Adob,Lad.	Reg,Buena	F,C	F,D	2-3
8	Casa	1927	Adob.	Buena	F	F	1
9	Casa	1940	Adob.	Reg.	F	F	2
11	Casa	1918	Adob.	Reg.	F	F	1
12	Mueblería	1991	Lad.	Buena	C	D	2
13	Casa	1953	Lad.	Buena	C	D	3
14	Casas	1925	Adob.	Reg.	F	F	1
15	Casa	1993	Lad.	Buena	C	D	1
17	Casa	1962	Adob.	Reg.	F	F	1
18	Casa	1959	Lad.	Buena	C	D	3
19	Quinta	1977	Lad.	Buena	C	D	3
20	Casas,Restaurante	1932	Adob.	Reg.	F	F	1,2
21	Casa Desocupada	1923	Adob.	Buena	F	F	1
22	Quinta	1967	Lad,Adob.	Buena,Reg.	C,F	D,F	2,3
23	Casas	1904	Adob.	Reg.	F	H	1
24	Casas	1904	Adob.	Malo	F	F	1
25	Callejón	1926	Adob.	Malo	F	F	1
26	Casa	1973	Lad.	Reg.	C	D	2
27	Quinta	1957,1943	Lad,Adob.	Buena,Reg.	C,F	D,F	2-3,1
28	Casa	1911	Adob.	Reg.	F	G	1
29	Casa	1936	Adob.	Buena	F	F	1
30	Casa Desocupada	1984	Lad.	Buena	C	D	1
31	Casa	1953	Adob.	Reg.	F	F	1

Manzana 40

Lote	Tipo de Usos	Año(s) de Contrucc.	Material	Estado	Muros	Techo	Pisos
1	Casa	1940	Adob.	Reg.	F	F	2
2	Casas	1942	Lad.	Buena	D	D	1
3	Quinta	1918	Adob.	Reg.	F	F	1
4	Casa	1918	Adob.	Reg.	F	F	1
5	Casas	1933	Adob.	Reg.	F	F	1
6	Casa	1956	Adob.	Buena	F	H	1

Manzana 42

Lote	Tipo de Usos	Año(s) de Contrucc.	Material	Estado	Muros	Techo	Pisos
3	Casa Desocupada	1920	Adob.	Reg.	F	F	2
4	Casa	1920	Adob.	Reg.	F	F	1
5	Casa	1928	Adob.	Reg.	F	H	1
6	Colegio, Negocio	1928, 1998	Adob, Lad	Reg, Bueno	F, C	F, D	2, 1
7	Casas	1956, 1960, 1960	Lad.	Bue, Reg, Bue.	C	D	3
8	Casa	1980	Lad.	Bueno	C	D	3
9	Casa	1902	Adob.	Reg.	F	H	1
10	Casas	1900	Adob.	Reg.	F	F	1
11	Casa	1943	Lad.	Bueno	C	D	2
12	Casas	1960, 1999	Lad.	Bueno	D, C	D, D	2, 3
13	Casa	1960	Lad.	Bueno	C	D	2
14	Casa	1982, 1965	Lad.	Bueno	C, D	D, D	2, 3
15	Casas	1973	Lad.	Bueno	C	D	2

Manzana 44

Lote	Tipo de Usos	Año(s) de Contrucc.	Material	Estado	Muros	Techo	Pisos
1	Casa	1913	Adob.	Reg.	F	F	1
2	Casas	1955, 1938-1954	Lad, Adob.	Reg.	C, F	D, F	1-3, 2
3	Casas	1956	Adob.	Reg.	F	F	1
4	Restaurante	1917	Adob.	Bueno	F	F	2
5	Casas	1943	Lad.	Reg.	C	F	1
6	Casa	1958	Adob.	Reg.	F	F	1
7	Casa	1958	Adob.	Reg.	F	F	1
8	Casa	1958	Adob.	Reg.	F	F	1

Manzana 48

Lote	Tipo de Usos	Año(s) de Contrucc.	Material	Estado	Muros	Techo	Pisos
2	Casa	1959	Lad.	Bueno	C, E	D, F	2
3	Casa	1912	Adob.	Reg	F	H	1
4	Casa	1929	Lad.	Bueno	C	D	4
5	Casa	1927	Adob.	Reg	F	F	1
6	Casas	1913	Adob.	Reg	F	F	1

Manzana 51

Lote	Tipo de Usos	Año(s) de Contrucc.	Material	Estado	Muros	Techo	Pisos
2	Casas	1917	Adob.	Reg	F	H	2
4	Casa	1980	Lad.	Bueno	C	D	1
5	Casa	1930	Adob.	Bueno	F	F	1
6	Casa	1964	Adob.	Bueno	F	F	1
8	Casas	1990, 1952	Lad, Adob.	Bueno	D, F	D, H	1
9	Casa	1934	Adob.	Reg	F	F	1
10	Casas	1910, 1924	Adob.	Reg, Malo	F	H	2
12	Casas	1970	Adob.	Bueno	F	F	1
13	Casas	1930	Adob.	Reg	F	H	1
15	Casa	1954	Lad.	Bueno	D	D	2

Manzana 53

Lote	Tipo de Usos	Año(s) de Contrucc.	Material	Estado	Muros	Techo	Pisos
1	Casas	1938	Adob.	Reg.	F	H	1
2	Casa	1968	Lad.	Bueno	C	D	3
3	Café Concert	1968	Adob.	Reg.	F	H	1
4	Sala Exposit., Casa	1976, 1998	Lad.	Bueno	C	D	2
5	Estacionamiento	1988	Lad.	Reg.	C	D	1
6	Casa	1963	Lad.	Reg.	D	D	2
7	Casas	1918, 1985-1997	Adob, Lad.	Reg, Bueno	F, C	F, D	1, 3
8	Casa	1941	Lad.	Reg.	C	D	2
9	Casa	1968	Lad.	Bueno	C	D	2
10	Casa	1928	Adob.	Bueno	F	H	1

Manzana 55

Lote	Tipo de Usos	Año(s) de Contrucc.	Material	Estado	Muros	Techo	Pisos
1	Casa	1904(1,2),1980(3)	Adob(1,2), Lad.	Reg.	F,F,D	F,F,D	3
2	Casa Desocupada	1910	Lad.	Reg.	D	D	1
3	Casas	1920	Lad.	Reg.	C	D	3
4	Peluquería	1936	Lad.	Reg.	C	D	1
5	Negocios	1947	Lad.	Reg.	C	D	2y3
6	Edificio	1973	C.A.	Bueno	B	D	6
7	Casa Desocupada	1970	Lad.	Reg.	C	D	1
8	Edificio	1931	Lad.	Reg.	C	D	3
9	Quinta	1929-1985	Lad.	Reg.	C	D	1-2
10	Parroquia	1929	C.A.	Reg.	B	D	1
11	Convento	1986	Lad.	Bueno	C	D	3
12	Casa	1984	Lad.	Bueno	C	D	4

Manzana 58

Lote	Tipo de Usos	Año(s) de Contrucc.	Material	Estado	Muros	Techo	Pisos
1	Casa	1985	Lad.	Bueno	C	D	2
2	Edificio	1999	C.A.	Muy Bueno	B	B	5
4	Casas	1975	Lad.	Bueno	C	D	2,3
5	Casa	1948	Lad.	Bueno	C	D	3
6	Taller,Casa	1938,1954	Adob.	Reg.	F	F	1,2
7	Edificio de Viv.	1995	C.A.	Muy Bueno	B	D	6
8	Casa	1902	Adob.	Bueno	F	F	3
9	Casas	1976	Lad.	Bueno,Reg.	C,D	D,F	2
10	Edificio	1960	Lad.	Bueno	C	D	3
11	Casa,Consult,Estud.	1932,1932,1961	Lad.	Reg,Reg,Buen	C	D	3,1,1
12	Quinta	1952-1984	Lad.	Bueno	C	D	2
13	Edificio	1999	C.A.	Muy Bueno	B	D	4
14	Casas	1933,1999	Adob,Lad.	Reg,Bueno	F,C	G,D	1,2
15	Casas	1940,1955	Lad.	Bueno,Reg.	C,F	D,F	2,1
16	Casa Desocupada	1940	Adob.	Malo	D	D	1
17	Edificio,Quinta	1997,1991	C.A.,Lad	Bueno	B,C	D	4,2

Manzana 60

Lote	Tipo de Usos	Año(s) de Contrucc.	Material	Estado	Muros	Techo	Pisos
1	Oficina	1958	C.A.	Muy Bueno	B	D	4
2	Casa,Restaurante	1950,1976	Adob.	Reg.	F	H	1,2
3	Negocios	1954	Adob.	Reg.	F	F	1
4	Casas	1954	Adob.	Reg.	F	F	1
5	Casa	1970	Adob.	Reg.	F	F	2
6	Taller, Albergue	1905	Adob.	Reg.	E	F	1
7	Casas,Quinta	1952,1953	Lad.	Reg.	C	D	2,1-3
8	Museo	1941	Lad.	Bueno	C	D	1
9	Casa	1900	Lad.	Reg.	C	F	1
10	Casas	1916	Adob.	Reg.	F	H	1
11	Biblioteca	1900	Adob.	Reg.	F	F	3

Manzana 64

Lote	Tipo de Usos	Año(s) de Contrucc.	Material	Estado	Muros	Techo	Pisos
1	Casa	1920	Adob.	Reg.	F	F	1
2	Casa	1972	Lad.	Bueno	C	D	2
3	Casa	1977	Lad.	Bueno	C	D	3
4	Casa,Colegio	1976	Lad.	Bueno	C	D	2
5	Casa	1980	Lad.	Bueno	C	D	3
6	Casa	1982	Lad.	Bueno	C	D	3
7	Casa	1980	Lad.	Bueno	C	D	2
8	Edificio de viv.	1985	Lad.	Bueno	C	D	4
10	Casa	1986	Lad.	Muy Bueno	C	D,C	2
11	Casa	1957	Lad.	Bueno	C	D	3
12	Edificio de viv.	1982	C.A.	Bueno	B	D	5
13	Casa	1970(1,2),1975(3),1987	Lad.	Reg.	C	D	4

Manzana 65

Lote	Tipo de Usos	Año(s) de Contrucc.	Material	Estado	Muros	Techo	Pisos
1	Casa	1971	Lad.	Bueno	C	D	3
2	Quinta	1973	Lad.	Reg.	F	F	1
3	Quinta	1954	Adob.	Malo	F	H	1
4	Casa	1900	Adob.	Reg.	F	F	1
6	Casas	1900,1999	Adob,C.A.	Reg,Bueno	F,B	F,B	1
7	Colegio,Promotora	1900,1970	Adob,Lad	Reg,Bueno	F,C	F,D	1,2
8	Casa	1914	Adob.	Reg.	F	F	1
9	Club FAP(2 bloques)	1940,1992	Adob,Lad	Reg,Bueno	F,C	G,D	1,3
10	Casa	1955	Lad.	Bueno	C	D	3
13	Casa	1933	Adob.	Reg.	F	F	1
14	Negocios	1930	Adob.	Reg.	F	F	1-2
16	Reparaciones	1902	Adob.	Reg.	F	F	1
17	Alojamiento	1917	C.A.	Bueno	B	D	4
18	Casa	1933	Adob.	Reg.	F	F	1
19	Restaurante	1994	Lad.	Muy Bueno	C	D	1
20	Quinta	1971	Lad.	Bueno	C	D	2-4
22	Casa	1976	Lad.	Bueno	C	D	1
24	Casa	1940	Adob.	Reg.	F	F	1
26	Casas	1940,1990	Adob,Lad	Mal,Reg.	F,C	F,D	1,2
27	Casa	1920	Adob.	Malo	F	F	1
28	Quinta	1901	Adob.	Malo	F	F	1
30	Casa	1965	Lad.	Bueno	C	D	2
31	Casa	1965	Lad.	Bueno	C	D	3
32	Quinta	1933	Adob.	Reg.	F	F	1
33	Casa	1920	Adob.	Reg.	F	F	1
34	Casa	1978	Lad.	Bueno	C	D	1
35	Casa	1979	Lad.	Bueno	C	D	3
36	Casa	1978	Lad.	Bueno	C	D	1
37	Casa	1978	Lad.	Bueno	C	D	3

Manzana 67

Lote	Tipo de Usos	Año(s) de Contrucc.	Material	Estado	Muros	Techo	Pisos
1	Casas	1976-1985	Lad.	Bueno	C	D	2
2	Casa	1984	Lad.	Bueno	C	D	2
3	Edificio	1982	Lad.	Bueno	C	D	4
4	Casa	1957	Lad.	Bueno	C	D	3
5	Casas	1925,1938	Adob.	Reg.	F	F,H	1
6	Casa Desocupada	1938	Adob.	Reg.	F	F	2
7	Casas	1947,1924-1999	Adob.	Reg.	F	F	1,3
8	Casa	1980	Lad.	Bueno	C	D	2

Manzana 69

Lote	Tipo de Usos	Año(s) de Contrucc.	Material	Estado	Muros	Techo	Pisos
1	Casas	1965	Lad.	Bueno	C	D	1
2	Estación Eléctrica	1958	Lad.	Bueno	C	D	1
3	Casa	1945	Lad.	Bueno	C	D	3
4	Casa	1958	Lad.	Bueno	C	D	1
5	Casa	1956	Lad.	Bueno	C	D	2
6	Casa	1959	Lad.	Bueno	C	D	3
7	Casa	1958	Lad.	Bueno	C	D	2
8	Casa	1985	Lad.	Bueno	C	D	3
9	Casa	1980	Lad.	Bueno	C	D	2
10	Casa	1956	Lad.	Bueno	C	D	2
11	Casa	1968	Lad.	Bueno	C	D	3
12	Casa	1956	Lad.	Bueno	C	D	3
13	Casa	1968	Lad.	Bueno	C	D	2
14	Casa	1956	Lad.	Bueno	C	D	2
15	Casa	1968	Lad.	Bueno	C	D	3
16	Casa	1956	Lad.	Bueno	C	D	3
17	Casa	1956	Lad.	Bueno	C	D	2
18	Casa	1986	Lad.	Bueno	C	D	2
19	Casa	1986	Lad.	Bueno	C	D	3

Manzana 70

Lote	Tipo de Usos	Año(s) de Contrucc.	Material	Estado	Muros	Techo	Pisos
1	Casa	1965	Lad.	Bueno	C	D	2
2	Casa	1966	Lad.	Bueno	C	D	3
3	Casa	1971	Lad.	Bueno	C	D	3
4	Casa	1971	Lad.	Bueno	C	D	3
5	Casa	1971	Lad.	Bueno	C	D	3
6	Casa	1971	Lad.	Bueno	C	D	3
7	Casa	1971	Lad.	Bueno	C	D	3
8	Casa	1971	Lad.	Bueno	C	D	3
9	Casa	1972	Lad.	Bueno	C	D	3
10	Casa Convento	1966	Lad.	Bueno	C	D	2
11	Teatro	1966	Lad.	Bueno	C	D	2
12	Casa Desocupada	1966	Lad.	Bueno	C	D	3
13	Casa,Oficina	1966	Lad.	Bueno	C	D	3
14	Quinta	1979	Lad.	Bueno	C	D	4
15	Edificio	1994	C.A.	Muy Bueno	C	D	5

Manzana 71

Lote	Tipo de Usos	Año(s) de Contrucc.	Material	Estado	Muros	Techo	Pisos
1	Casas	1967	Lad.	Bueno	C	D	3
2	Casas	1931	Lad.	Reg.	D	D	2
3	Casa	1932,1948	Lad.	Reg.	D	D	2
4	Quinta	1963	Lad.	Bueno	C	D	2-3
5	Quinta	1939	Adob.	Reg-Malo	F	F	1-2
6	Casas	1960,1939	Lad,Adob.	Bueno,Reg.	C,F	D,G	1
7	Casas	1983,1941	Lad,Adob.	Bueno,Reg.	C,F	D,H	1
8	Quinta	1972	Lad.	Bueno-Reg.	C	D	3
9	Casa	1960	Adob.	Reg.	F	H	1
10	Quinta	1979-1984	Lad.	Bueno	C	D	3
11	Quinta	1939	Adob.	Reg.	F	F	1
12	Casa	1938	Adob.	Reg.	F	F	1
13	Casa	1920	Adob.	Malo	F	F	1
14	Casa	1980	Lad.	Bueno	C	D	3
15	Casa	1927	Adob.	Reg.	F	F	1
16	Casas	1930,1999	Adob,Lad.	Bueno	F,C	F,D	2
17	Casa	1970,1978	Adob,Lad.	Reg,Bueno	F,C	F,D	1,2
18	Museo	1907-1999	Adob-Lad	Reg	F-C	F-D	1
19	Casa	1947	Adob.	Reg.	F	F	2
20	Casas, Quinta	1947,1969	Lad,Adob.	Bueno,Reg.	D,F	F,F	2
21	Casa	1988	Adob.	Reg.	F	F	1
22	Casa	1902	Adob.	Reg.	F	F	1
23	Casas	1910	Adob.	Reg.	F	F	2

Manzana 72

Lote	Tipo de Usos	Año(s) de Contrucc.	Material	Estado	Muros	Techo	Pisos
1	Casas	1940-1971	Lad.	Bueno	D	D	2,1
2	Negocio	1939	Lad,Adob	Reg	D,F	E,F	1
3	Quinta	1959-1978	Adob.	Reg.	F	F	1-2
4	Casas	1965,1950	Lad,Adob	Bueno,Reg.	C,F	D,F	2,1
5	Casa	1945,1963	Lad,Adob	Reg,Bueno	C,F	D,F	2,1
6	Casa	1943	Lad,Adob	Reg,Bueno	C,F	D,F	3,1
7	Casa	1984,1999	Lad.	Bueno	C	D	2
8	Casa	1946	Lad.	Bueno	C	D	3
9	Casa	1925,1983	Lad.	Reg.	C	F,G	2
10	Casas	1950	Lad.	Bueno,Reg.	C,D	D,F	3,1
11	Casa	1998	Lad.	Muy Bueno	C	D	3
12	Casas	1948	Adob.	Reg-Malo	F	F	1
13	Casas	1932	Adob.	Reg.	F	F	1-2
14	Casas	1950	Adob.	Reg.	F	F	1
15	Quinta	1939-1944	Adob,Lad.	Reg.	F,C	F,D	1
17	Casa	1962	Lad.	Bueno	C	D	3
18	Casa	1947	Lad.	Reg.	C	D	2
19	Casa	1956	Lad.	Reg.	C	D	2
20	Casa	1973	Lad.	Reg.	C	D	2
21	Casa	1970	Lad.	Reg.	C	D	3
22	Quinta	1942	Adob.	Reg.	F	F	1
23	Casa	1930	Adob.	Bueno	F	F	1
24	Casas	1944	Lad.	Bueno	D	D	1
25	Casa	1991	Lad.	Bueno	C	D	4
26	Quinta	1921	Adob.	Reg.	F	F	1-2
27	Casas	1939	Lad.	Reg.	D	D	2

Manzana 74

Lote	Tipo de Usos	Año(s) de Contrucc.	Material	Estado	Muros	Techo	Pisos
1	Casa	1957	Lad.	Reg.	C	D	1
2	Casa	1956	Lad.	Reg.	D	F	1
3	Casa	1960	Lad.	Reg.	D	D	1
4	Casa	1936	Lad.	Reg.	C	D	3
5	Casa	1974	Lad.	Reg.	C	D	3
6	Casa	1961	Lad.	Reg.	C	D	3
7	Casa	1957	Lad.	Reg.	C	D	2
8	Casa	1957	Lad.	Reg.	D	D	3
9	Casa	1958	Lad.	Reg.	C	D	3
10	Quinta	1960	Lad.	Reg.	C	D	3
11	Casas	1971-1986	Lad.	Bueno	C	D	3-1
13	Colegio Inicial	1999	Adob.	Bueno	F	F	1
14	Edificio de Viv.	1963	Lad.	Reg.	C	D	3
15	Edificio de Viv.	1959	Lad.	Reg.	C	D	4
16	Casa	1963	Lad.	Bueno	C	D	2

Manzana 76

Lote	Tipo de Usos	Año(s) de Contrucc.	Material	Estado	Muros	Techo	Pisos
1	Casa	1991	Lad	Bueno	C	D	2
2	Casa	1961	Lad	Bueno	C	D	3
3	Casa	1965	Lad	Reg.	C	D	3
4	Grifo	1963	Lad	Reg.	C	D	1
5	Panaderia,Casa	1979	Lad	Reg.	C	D	1,2
7	Casa	1960	Lad	Reg.	C	D	2
8	Quinta	1958	Lad	Reg.	C	D	3
9	Casa	1961	Lad	Bueno	C	D	3
10	Casa	1965	Lad	Bueno	C	D	2
11	Negocio	1965	Lad	Bueno	D	D	1
13	Casa	1963	Lad	Reg.	C	D	3
14	Casa	1963	Lad	Reg.	C	D	3
15	Casa	1963	Lad	Reg.	C	D	3
16	Casa	1957	Lad	Bueno	C	D	2
17	Casa	1962	Lad	Reg.	C	D	2
18	Casa	1958	Lad	Bueno	C	D	3
19	Casa	1959	Lad	Reg.	C	D	2
20	Casa	1960	Lad	Bueno	C	D	3

Manzana 78

Lote	Tipo de Usos	Año(s) de Contrucc.	Material	Estado	Muros	Techo	Pisos
1	Casa	1954	Lad.	Bueno	C	D	3
2	Libreria	1953	Lad.	Bueno	C	D	2
3	Oficina	1947	Lad.	Bueno	C	D	2
4	Asistencia Social	1949	Lad.	Bueno	C	D	2
5	Casa	1951	Lad.	Reg.	C	D	2
6	Casa	1954	Lad.	Bueno	C	D	2
8	Casas,Panaderia	1957-1964,1953	Lad.	Reg.	C	D	3,1
9	Quinta	1993	Lad.	Reg.	C	G	1
10	Casa	1952	Lad.	Reg.	D	E	1
11	Quinta	1952	Adob.	Malo	F	F	1
12	Casa	1963	Lad,Adob	Reg.	C,F	F	1
13	Quinta	1955	Lad.	Bueno	C	D	1
14	Casa Desocupada	1992	Lad.	Reg.	C	D	1
15	Quinta	1965	Lad.	Reg.	C	D	2
16	Edificio de Viv.	1969	Lad.	Bueno	C	D	3
17	Quinta	1956-1966	Lad.	Reg.	C	D	1-2
19	Quinta	1968-1970	Lad.	Reg.	C	D	2-3
20	Quinta	1952	Lad.	Bueno	C	D	2
21	Quinta	1990	Lad.	Reg.	C	D	3
22	Casa	1956	Lad.	Reg.	C	D	3
23	Casa	1958	Lad.	Bueno	C	D	3
24	Casa Desocupada	1997	Lad.	Bueno	C	D	1

Manzana 80

Lote	Tipo de Usos	Año(s) de Contrucc.	Material	Estado	Muros	Techo	Pisos
1	Colegio(2 Bloques)	1960,1992	C.A.	Bueno	B	D	2,1

Anexo II

Cuadros de cantidades y porcentajes de edificaciones con respecto a la manzana que pertenecen según Número de Pisos, Antigüedad y Tipos de Usos para cada uno de los tres sectores del distrito

Clasificación Por Número de Pisos

Cantidad de Edificaciones por Manzana

Según Tipo

Sector 1

Clasificación	Tipo A					Tipo B					Tipo C					Tipo D										
Material	Concreto Armado					Ladrillo Con Columna					Ladrillo Con Columna					Ladrillo Sin Columna										
Estado	Bueno-Muy Bueno					Bueno-Muy Bueno					Regular-Malo					Bueno										
Manzana	1plso	2pisos	3pisos	4 pisos a más	Total	1plso	2pisos	3pisos	4 pisos a más	Total	1plso	2pisos	3pisos	4 pisos a más	Total	1plso	2pisos	3pisos	Total	1plso	2pisos	3pisos	Total	1plso	2pisos	Total
1		1			1	1	7	5		13							1		1		1			1	1	1
2		1			1		1	5		6		3	2		5									1		1
3			1	1	2		3	7		10	1	4	3		8											
4							7	12		19		5	6		11											
8				2	2		1			1		2	1		3				1		1		5	1	6	
11	2		1	1	4		2	4		6	2	2			4											
13						1		5	1	7			1		1	1			1		5		5	1	1	
15				2	2	2		2		4		3	1		4				1		1		3		3	
19				4	4	1	4	3		8	1	2	1		4		1		1							
23			1		1		1	1	1	3	1	2	1		4				1	1		2	8		8	
25				1	1			2		2		2	1		3	1	1	1	3		2		2	1	3	
26								1		1			1		1								9		9	
27						2	1	1	1	5		1			1		1		1		1		5	3	8	
29						1	1	2	1	5	3	1			4	1			1	1		1	6		6	
30				2	2	1	1	1		3	1	1	2		4								12		12	
32				1	1	1	2	5		8			1		1								1		1	
33						1	1	1		3			2		2			1		1		1	8		8	
34						1	4	3	1	9	5	6	5		16				1		1	4	2	6		
39							15	22		37																
40		1			1	2	5	9	1	17	1				1								11	1	12	
41						2	2	2	1	7	1	2			3		2		2	1		2	3	4	4	
43	1				1	1	2	1		4			1		1	1			1				6		6	
45	1			5	6	2	5	6		13	1	1		1	3											
48			1	1	2		4	9	1	14									1	1		2				
51							2	1		3	1				1				1		1		1		1	
53							1	3		4	1	2	3		6					1		1	4	1	5	
56							2			2																
57		1			1		8	3		11		2			2					3	1	4				
61				1	1	3	9	3		15		1			1		1	2	3	1		1	4		4	
63		1			1	3	1	4		8	1	1			2	1			1			6	2	8		
64			1	1	2	3	3	14		20		2			2		1	1	2							
65				1	1																					
Totales	4	5	5	23	37	28	95	137	8	268	20	45	32	1	98	5	9	4	18	16	9	3	28	101	12	113

Sector 2

Clasificación		Tipo A					Tipo B					Tipo C					Tipo D										
Material		Concreto Armado					Ladrillo Con Columna					Ladrillo Con Columna					Ladrillo Sin Columna				Adobe						
Estado		Bueno-Muy Bueno					Bueno-Muy Bueno					Regular-Malo					Bueno				Regular-Malo				Regular-Malo		
Manzana	Pisos	1plso	2pisos	3pisos	4 pisos a más	Total	1plso	2pisos	3pisos	4 pisos a más	Total	1plso	2pisos	3pisos	4 pisos a más	Total	1plso	2pisos	3pisos	Total	1plso	2pisos	3pisos	Total	1plso	2pisos	Total
		1						1		1		2	3		1	4						3			3	6	
2							2			2										1	1		2	6	1	7	
3											1			1						2	1		3	8		8	
4			1	1	2	2	1			3	2	1		3										6		6	
5											2	1	1	4						2			2	8		8	
6		1			1	1				1	2			2										5	1	6	
7							1			1	6	2		8						5			5	2		2	
9			1		1	1		2		3	1	2		3										9		9	
10							2			2		1		1										9		9	
11							1			1	2	1		3										4		4	
12							2			2	5		1	6	2			2		3			3	3		3	
14								1		1	4	1		5						1			1	11		11	
16						1	2			3	1			1										6	2	8	
17						1		1		2	1			1	2	1		3		1	4	2	7	8	1	9	
19						2		1		3	1	3	1	5	3			3		3			3				
20						3	1	1		5	1			1										4	2	6	
23			1		1	2	1	1		4	2		1	3			1	2	3		1		1	12	1	13	
26							1			1	1			1				1	1					7	1	8	
27						2	1	1		4	2			2						2			2	11		11	
28								2		2	1			1						1			1	9		9	
31							1			1										1			1	6		6	
32						1		1		2		2		2			1		1					7	1	8	
34						1		1		2														7		7	
37						3	2	2		7					1			1					1	11		11	
39						1	1	1		3	2		1	3										6	1	7	
40						2	2			4	1			1						2			2	21		21	
42						1	1	1		3					1			1	1				1	8	1	9	
43						1		1		2			1	1	2									34		34	
44								1	1	2														14		14	
45								1		1						1	1		2	1			1	17		17	
47						1	1	2		4	1	2	1	4	1			1						17		17	
50	1				1	3		2		5	1			1	1			1					8	1	9		
51						1				1	1			1	1			1						23		23	
52			1	1	2	3	1	2		6	3			3						1			1	19		19	
53						5		1		6	1			1				1						11		11	
54			1		1												1		1								
55							1			1	2		1	3						3			3	14		14	
56								4		4					1			1						15	1	16	
57						3	1			4			1	1	2			2	1				1	6		6	
58							1			1	2	2	4	8	1	1		2						11		11	
59						1	1	1		3		3	2	5				2	2				2	7	1	8	
60			1	1	2	8	10			20		4	8	12						1			1	22	2	24	
61			1	1	2	1		1		4	4		3	7						1			1	8		8	
62						1		3		4	6		1	7						2	2		4	6		6	
Totales		1	1	4	5	11	48	37	45	2	132	62	25	28	1	116	18	6	5	29	39	9	4	52	432	17	449

Sector 3

Clasificación		Tipo A					Tipo B					Tipo C					Tipo D											
Material		Concreto Armado					Ladrillo Con Columna					Ladrillo Con Columna					Ladrillo Sin Columna				Adobe							
Estado		Bueno-Muy Bueno					Bueno-Muy Bueno					Regular-Malo					Bueno				Regular-Malo		Regular-Malo					
Manzana	Pisos	1plso	2pisos	3pisos	4 pisos a más	Total	1plso	2pisos	3pisos	4 pisos a más	Total	1plso	2pisos	3pisos	4 pisos a más	Total	1plso	2pisos	3pisos	Total	1plso	2pisos	3pisos	Total	1plso	2pisos	Total	
	3				1	1	2		1	1	2		2	1		3						1		1	3	7	10	
4				2		2						2		2		4								1	1	2		
6				1	2	3						1	4		5										2	2		
8			2	1		3	1		2	3			1		1				1	1				1	1	2		
9			1			1		1	1	2	3			1	4	4	1			5	1	1		2	8	1	9	
11				1		1	1	2	2	5				2	2						1		1	2	5	1	6	
13								8	5	13			1	2	3													
15							1		2	3	2	2			4										9		9	
19				1		1	1	1	1	3															1		1	
20				1		1	1	1	4	6			1		1	2								2	6		8	
21		1			1	2	1	3	1	5	1	2			3					2		1		1	6	4	10	
23							1			3	2	1	1		4										17	2	19	
24							1		2	3		6	2		8										11	2	13	
25				1	3	4	1	6	2	9			1	1	2										8	4	12	
27				1	1	2	1	2	1	4															14	4	18	
29								1	2	3	1	1			2										9	2	11	
31		1	2	2		5		3	2	5																		
34		1			1	2											1			1					3	3	6	
35																					1				1		1	
38		1		2	1	4	1	3	9	1	14														6	3	9	
39							1	2	3	3	9		1		1		1			1					22	2	24	
40																	3			3					5	1	6	
42							2	4	3	9			1		1			1	1	2					4	2	6	
44											1		1		2											5	2	7
48								1		2																3		3
51							1			1							1	1		2					5	3	8	
53							1	2	2	5	1	1			2							1			5		5	
55				1		1	1	2	2	3	4	2	3		9						1			1		1	1	
56			2		2	4	1	2	2	5		2		2											19	2	21	
58				4		4	1	6	3	10	1		1		2						1			1	4	2	6	
60		1				1	1			1	1	1	1		3										7	3	10	
64				1		1		4	5	1	10			1	1										1		1	
65		1			1	2		3	3	8	1				1										14	2	16	
67							1	3	1	6															2	2	4	
69							3	8	8	19																		
70				1		1		3	11	14																		
71							1	3	5	9	1	2			3										2		15	
72								2	4	1	7	1	5	2		8	3	1		4	2	1		3	10	2	12	
74							1	1	1	3	1	1	6	1	9						2		1	3	1		1	
76								4	4	8	2	3	5		10	1				1								
78							2	5	3	10	3	4	4		11						1			1	2		2	
80		1	1			2																						
Totales		7	8	9	25	49	31	85	100	12	228	29	43	37	2	111	16	4	2	22	9	8	2	19	222	74	296	

Clasificación Por Antigüedad

Cantidad de Edificaciones por Manzana Según Tipo

Sector 1

Clasificación Material Estado	Tipo A					Tipo B					Tipo C										Tipo D											
	Concreto Armado					Ladrillo Con Columna					Ladrillo Con Columna					Ladrillo Sin Columna					Ladrillo Sin Columna					Adobe						
	Bueno-Muy Bueno					Bueno-Muy Bueno					Regular-Malo					Bueno					Regular-Malo					Regular-Malo						
Años	1941 a 1966	1967 a 1974	1975 a 1983	1984 a 2000	Total	1941 a 1966	1967 a 1974	1975 a 1983	1984 a 2000	Total	1941 a 1966	1967 a 1974	1975 a 1983	1984 a 2000	Total	1941 a 1966	1967 a 1974	1975 a 1983	1984 a 2000	Total	1941 a 1966	1967 a 1974	1975 a 1983	1984 a 2000	Total	1941 a 1966	1967 a 1974	1975 a 1983	1984 a 2000	Total		
1	1				1	12				13											1										1	
2		1			1	4	1		1	6			1	1	9																1	
3				2	2	8	1		1	10			7	1	8																1	
4						15	3	1		19			9	2	11																	
8		1	1		2		1			1			2	1	3						1					1	2	4			6	
11		1	1	2	4	2	2	1	1	6			2	2	4						1	1									1	
13						5		1	1	7	1				1																1	
15				2	2	2	1		1	4			2		4																3	
19				4	4	7	1			6			4		4						1										3	
23				1	1	2			1	3			4		4																8	
25				1	1	2				2	1		2		3						3	1									3	
26						1				1			1		1																3	
27						1	2	1		1	5	1			1						1	1	1								8	
29						1	3		1	5			3		4						1										6	
30	1			1	2	1	1		1	3			2	1	4																12	
32				1		1	6	1		3			1		1																1	
33							2		1	3			2		2						1										8	
34						5		1	3	9			13		16						1										6	
39						4	18	11	4	37					1																1	
40	1				1	6	6	2	3	17					1																12	
41						5		1	1	7					3						1										4	
43				1	1	2	1		1	4			1		1						1										6	
45				6	6	6	6	1		13			2	1	3																6	
48			2		2	12	1		1	14																					6	
51									2	1			3		1																1	
53						1	2	1		4	2		2		6						1										5	
56									1	1			2		1																1	
57			1		1	1	10			11			2		2																4	
61				1	1	7	3	4	1	15			1		1						3										4	
63				1	1	4		2	2	9			2		2																8	
64			2		2	6	12	2		20			1	1	2						2										8	
65				1		1				1					1																	1
Totales	3	7	5	22	37	1	124	82	32	29	5	67	13	3	10	98	13	2		3	16	10	16	2		36	41	62	5	4	1	113

Clasificación Por Tipo De Usos

Cantidad de Edificaciones por Manzana

Según Tipo

Sector 1

Clasificación	Tipo A					Tipo B					Tipo C					Tipo D				Tipo D				
Material	Concreto Armado					Ladrillo Con Columna					Ladrillo Con Columna / Sin Columna					Ladrillo Sin Columna				Adobe				
Estado	Bueno-Muy Bueno					Bueno-Muy Bueno					Regular-Malo			Bueno		Regular-Malo				Regular-Malo				
Usos Manzana	C.	Q.	T.	E.	Total	C.	Q.	T.	E.	Total	C.	Q.	T.	E.	Total	C.	Q.	T.	Total	C.	Q.	T.	E.	Total
1	1				1	9	3	1		13	1				1	1			1			1		1
2	1				1	6				6	4	1			5							1		1
3				2	2	8		1	1	10	8				6									
4						19				19	11				11									
8	1		1		2	1				1	2		1		3	1			1	4	1	1		6
11	1		1	2	4	5			1	6	2		2		4									
13						5		1	1	7	2				2	5			5	1				1
15				2	2	4				4	3	1			4	1			1	3				3
19				4	4	6			2	8	3	2			5									
23				1	1		3			3	3	1			4		2		2	7	1			8
25				1	1	2				2	2	2		2	6	2			2	3				3
26						1				1		1			1				7	2				9
27						4		1		5		2			2	1			1	5	2	1		8
29						3	1		1	5	5				5	1			1	4	2			6
30				2	2	1		1	1	3	1	1	1	1	4				8	2	2			12
32				1	1	3			4	8	1				1				1					1
33						2		1		3		3			3		1		1	6	2			8
34						5	1	3		9	11	1	4		16		1		1	5	1			6
39						37				37														
40				1	1	10	5	1	1	17	1				1				9	2	1			12
41						4	3			7	4		1		5	3			3	1	3			4
43	1				1		2	1	1	4	2				2				5			1		6
45				2	4	6	11	1	1	13	2	1			3									
48				2	2	8	3	1	2	14						1		1	2					
51						3				3	1				1	1			1					1
53						4				4	5		1		6			1	1	3	2			5
56								2		2														
57				1	1	11				11	2				2	3		1	4					
61				1	1	11	1	3		15	2	1	1		4		1		1	2	2			4
63				1	1	3		5		8	1	1	1		3				3	1	4			8
64	1			1	2	15	4	1		20	3	1			4									
65				1	1																			
Totales	6		6	25	37	201	27	28	12	268	82	19	12	3	116	20	5	3	28	78	23	12		113

Sector 2

Clasificación	Tipo A					Tipo B					Tipo C					Tipo D				Tipo D					
Material	Concreto Armado					Ladrillo Con Columna					Ladrillo Con Columna / Sin Columna					Ladrillo Sin Columna				Adobe					
Estado	Bueno-Muy Bueno					Bueno-Muy Bueno					Regular-Malo		Bueno			Regular-Malo				Regular-Malo					
Usos Manzana	C.	Q.	T.	E.	Total	C.	Q.	T.	E.	Total	C.	Q.	T.	E.	Total	C.	Q.	T.	Total	C.	Q.	T.	E.	Total	
1						1		1		2				4			1	2	3	3	3			6	
2						1		1		2						1		1	2	3	4			7	
3												1			1		2		3	3	5			8	
4			2		2	2		1		3	1	2			3					2	4			6	
5											2	1	1		4		2		2	3	4	1		8	
6		1			1		1			1		1	1		2				4	1	1			6	
7								1		1				8				5	5		1	1			2
9				1	1	3				3	1	1		1	3					4	5			9	
10								2		2			1		1					2	7			9	
11						1				1	2	1			3				2	2				4	
12						1		1		2	2	1	4	1	8	3			3	2		1		3	
14									1	1	4	1			5			1	1	6	4	1		11	
16						2	1			3	1				1				5	2	1			8	
17							1		1	2	4				4	7			7	1	8			9	
19						1		2		3	4		4		8	2		1	3						
20						3	1	1		5			1		1				2	3	1			6	
23		1			1	2		2		4	4		1	1	6	1			1	7	1	5		13	
26						1				1	2				2				6	1	1			8	
27						4				4	1		1		2	1		1	2	7	4			11	
28						1		1		2	1				1		1		9					9	
31						1				1					1			1	3	3				6	
32						2				2	3				3				5	2	1			8	
34						1		1		2									5	2				7	
37						7				7	1				1	1		1	10	1				11	
39						2		1		3	3				3				6		1			7	
40			1		1	1	1	1	1	4	1				1	1	1	2	15	5	1			21	
42						2	1			3		1			1		1		5	4				9	
43						1		1		2		1		1	2				16	18				34	
44							1		1	2									11	2	1			14	
45						1				1	1	1			2	1		1	11	5	1			17	
47						2	1	1		4	1	2	1	1	5				12	4	1			17	
50			1		1	5				5	2				2				8	1				9	
51						1				1		1	1		2				13	10				23	
52				1	1	3		3		6	2	1			3			1	1	12	4	3		19	
53						5	1			6	2				2				3	7	1			11	
54				1	1									1	1										
55						1				1	3				3	1	2		3	8	4	2		14	
56						1	3			4	1				1				9	5	2			16	
57						1		3		4	1		2		3	1		1	2		4			6	
58						1				1	4	5	1		10				5	6				11	
59						3				3	6	1			7	1		1	5	2	1			8	
60	1				1	18	2			20	12				12	1		1	22	2				24	
61				1	1	2	1	1		4	5		1	1	7	1			2	5	1			8	
62						3	1			4	7				7	1	2	1	4	4	2			6	
Totales	1	2	4	4	11	87	16	25	4	132	84	22	32	7	145	27	10	15	52	263	153	33		449	

Sector 3

Clasificación	Tipo A					Tipo B					Tipo C					Tipo D				Tipo D				
Material	Concreto Armado					Ladrillo Con Columna					Ladrillo Con Columna / Sin Columna					Ladrillo Sin Columna				Adobe				
Estado	Bueno-Muy Bueno					Bueno-Muy Bueno					Regular-Malo			Bueno		Regular-Malo				Regular-Malo				
Usos Manzana	C.	Q.	T.	E.	Total	C.	Q.	T.	E.	Total	C.	Q.	T.	E.	Total	C.	Q.	T.	Total	C.	Q.	T.	E.	Total
3	1			1	2	2				2	2	1			3	1			1	10				10
4				2	2						4				4					2				2
6				3	3						5				5					2				2
8			1	2	3	2		1		3		1		1	2				1			1		2
9			1		1	2				2	7		2		9		1	1	2	5	2	2		9
11				1	1	5				5	2				2	2			2	4	2			6
13						11		2		13	1		2		3									
15						3				3	4				4				8	1				9
19				1	1	2		1		3												1		1
20				1	1	5	1			6	3				3				6			2		8
21				2	2	2		2	1	5	1	1	1		3		1		1	8		2		10
23						1			2	3	3	1			4				15	3	1			19
24						3				3	6		2		8				10	1	2			13
25				4	4	9				9			2		2				9	1	2			12
27			1	1	2	1	1	2		4									10	1	7			18
29						3				3	2				2				9		2			11
31	4			1	5	4	1			5														
34			1	1	2						1				1				5		1			6
35																	1	1				1		1
38			2	2	4	11	1	1	1	14									5	1	3			9
39						4	4	1		9	2				2				19	4	1			24
40											3				3				5	1				6
42						8		1		9	3				3				5		1			6
44											2				2				6		1			7
48						2				2									3					3
51						1				1	2				2				8					8
53						4		1		5	1		1		2	1			1	3		2		5
55				1	1	2		1		3	4	1	3	1	9	1			1	1				1
56			2	2	4	2	1	1	1	5			2		2				3	4	14			21
58				4	4	6	2	1	1	10	1		1		2	1			5		1			6
60			1		1			1		1	2	1			3				5		5			10
64				1	1	8		1	1	10	1				1				1					1
65	1			1	2	9	2	3		14	1				1				8	3	5			16
67						5			1	6									4					4
69						18		1		19														
70				1	1	13			1	14														
71						5	3	1		9	2		1		3	2			2	12	3			15
72						7				7	10	1	1		12	2		1	3	8	4			12
74						3				3	6	1		2	9	3					1			1
76						8				8	7	1	3		11									
78						3	2	3	2	10	4	5	2		11	1			1	1	1			2
80			2		2																			
Totales	6		11	32	49	174	18	25	11	228	92	14	23	4	133	14	2	3	19	206	32	58		296

Porcentajes de Edificaciones por Manzana

Según Tipo

(Porcentajes hechos en base al total de cada manzana)

Sector 1

Clasificación	Tipo A					Tipo B					Tipo C					Tipo D				Tipo D					
	Concreto Armado					Ladrillo Con Columna					Ladrillo Con Columna / Sin Columna					Ladrillo Sin Columna				Adobe					
Material																									
Estado	Bueno-Muy Bueno					Bueno-Muy Bueno					Regular-Malo					Regular-Malo				Regular-Malo					
Usos	C.	Q.	T.	E.	Total	C.	Q.	T.	E.	Total	C.	Q.	T.	E.	Total	C.	Q.	T.	Total	C.	Q.	T.	E.	Total	
Manzana																									
1	5.9%				5.88%	52.9%	17.6%	5.9%			76.47%	5.9%				5.88%	5.9%			5.88%				5.9%	5.88%
2	7.7%				7.69%	46.2%				46.15%	30.8%	7.7%			38.45%									7.7%	7.69%
3				10.0%	10.00%	40.0%		5.0%	5.0%	30.00%	40.0%				40.00%										
4						63.3%				53.33%	36.7%				36.67%										
8	7.7%		7.7%		15.38%	7.7%				7.69%	15.4%		7.7%		23.08%	7.7%			7.69%	30.8%	7.7%	7.7%			46.15%
11	7.1%		7.1%	14.3%	28.57%	35.7%			7.1%	42.86%	14.3%		14.3%		26.57%										
13						33.3%		6.7%	6.7%	46.67%	13.3%				13.33%	33.3%			33.33%	6.7%					6.67%
15				14.3%	14.29%	28.6%				28.57%	21.4%	7.1%			28.57%	7.1%			7.14%	21.4%					21.43%
19				23.5%	23.53%	35.3%			11.8%	47.06%	17.6%	11.8%			29.41%										
23				5.6%	5.56%		16.7%			16.67%	16.7%	5.6%			22.22%		11.1%		11.11%	38.9%	5.6%				44.44%
25				7.1%	7.14%	14.3%				14.29%	14.3%	14.3%		14.3%	42.86%	14.3%			14.29%	21.4%					21.43%
26						9.1%				9.09%		9.1%			9.09%					63.6%	18.2%				81.82%
27						25.0%		6.3%		31.25%		12.5%			12.50%	6.3%			6.25%	31.3%	12.5%	6.3%			50.00%
29						17.6%	5.9%		5.9%	29.41%	29.4%				29.41%	5.9%			5.88%	23.5%	11.8%				35.29%
30				9.5%	9.52%	4.8%		4.8%	4.8%	14.29%	4.8%	4.8%	4.8%	4.8%	19.05%					38.1%	9.5%	9.5%			57.14%
32				9.1%	9.09%	27.3%		36.4%	9.1%	72.73%	9.1%				9.09%					9.1%					9.09%
33						13.3%		6.7%		20.00%		20.0%			20.00%		6.7%		6.67%	40.0%	13.3%				53.33%
34						15.6%	3.1%	9.4%		28.13%	34.4%	3.1%	12.5%		50.00%		3.1%		3.13%	15.6%	3.1%				18.75%
39						100.0%				100.0%															
40				3.2%	3.23%	32.3%	16.1%	3.2%	3.2%	54.84%	3.2%				3.23%				15.79%	5.3%	15.8%				21.05%
41						21.1%	15.8%			36.84%	21.1%	5.3%			26.32%	15.8%									
43	7.7%				7.69%	15.4%	7.7%	7.7%		30.77%	15.4%				15.38%					38.5%		7.7%			46.15%
45			9.1%	18.2%	27.27%	50.0%	4.5%	4.5%		59.09%	9.1%	4.5%			13.64%										
48				11.1%	11.11%	44.4%	16.7%	5.6%	11.1%	77.78%						5.6%		5.6%	11.11%						16.67%
51						50.0%				50.00%	16.7%				16.67%	16.7%									16.67%
53						25.0%				25.00%	31.3%		6.3%		37.50%				6.3%	6.25%	18.8%	12.5%			31.25%
56								100.0%		100.0%															
57			5.6%		5.56%	61.1%				61.11%	11.1%				11.11%	16.7%		5.6%	22.22%						
61				4.0%	4.00%	44.0%	4.0%	12.0%		60.00%	8.0%	4.0%	4.0%		16.00%		4.0%		4.00%	8.0%	8.0%				16.00%
63			5.0%		5.00%	15.0%		25.0%		40.00%	5.0%	5.0%	5.0%		15.00%					15.0%	5.0%	20.0%			40.00%
64	3.8%			3.8%	7.69%	57.7%	15.4%	3.8%		76.92%	11.5%	3.8%			15.38%										
65				100.0%	100.0%																				

Sector 2

Clasificación	Tipo A					Tipo B					Tipo C					Tipo D				Tipo D						
	Concreto Armado					Ladrillo Con Columna					Ladrillo Con Columna / Sin Columna					Ladrillo Sin Columna				Adobe						
Material																										
Estado	Bueno-Muy Bueno					Bueno-Muy Bueno					Regular-Malo			Bueno		Regular-Malo				Regular-Malo						
Usos	C.	Q.	T.	E.	Total	C.	Q.	T.	E.	Total	C.	Q.	T.	E.	Total	C.	Q.	T.	Total	C.	Q.	T.	E.	Total		
Manzana																										
1						6.7%		6.7%		13.33%			26.7%		26.67%			6.7%	13.3%	20.00%	20.0%	20.0%			40.00%	
2						9.1%		9.1%		18.18%						9.1%		9.1%	18.18%	27.3%	36.4%				66.67%	
3												8.3%			8.33%	16.7%		8.3%	25.00%	25.0%	41.7%				66.67%	
4			14.3%		14.29%	14.3%		7.1%		21.43%	7.1%	14.3%			21.43%					14.3%		14.29%			42.86%	
5											14.3%	7.1%	7.1%		28.57%			14.3%		14.29%	21.4%	28.6%	7.1%		57.14%	
6		10.0%			10.00%		10.0%			10.00%		10.0%	10.0%		20.00%					40.0%	10.0%	10.0%			60.00%	
7								6.3%		6.25%			50.0%		50.00%			31.3%	31.25%		6.3%	6.3%			12.50%	
9				6.3%	6.25%	18.8%				18.75%	6.3%	6.3%		6.3%	18.75%					25.0%	31.3%				56.25%	
10								16.7%		16.67%			8.3%		8.33%					16.7%	58.3%				75.00%	
11						12.5%				12.50%	25.0%	12.5%			37.50%					25.0%	25.0%				50.00%	
12						6.3%		6.3%		12.50%	12.5%	6.3%	25.0%	6.3%	50.00%	18.8%			18.75%	12.5%			6.3%		18.75%	
14									5.6%	5.56%	22.2%	5.6%			27.78%				5.6%	5.56%	33.3%	22.2%	5.6%		61.11%	
16						16.7%	8.3%			25.00%	8.3%				8.33%					41.7%	16.7%	8.3%			66.67%	
17							4.5%		4.5%	9.09%	18.2%				18.18%	31.8%			31.82%	4.5%	36.4%				40.91%	
19						7.1%		14.3%		21.43%	28.6%			28.6%	57.14%	14.3%		7.1%	21.43%	16.7%	25.0%	8.3%			50.00%	
20						25.0%	8.3%	8.3%		41.67%			8.3%		8.33%					16.7%	25.0%	8.3%			50.00%	
23		4.0%			4.00%	8.0%	8.3%	8.0%		16.00%	16.0%		4.0%	4.0%	24.00%	4.0%			4.00%	28.0%	4.0%	20.0%			52.00%	
26						9.1%				9.09%	18.2%				18.18%					54.5%	9.1%	9.1%			72.73%	
27						21.1%				21.05%	5.3%	5.3%			10.53%	5.3%		5.3%	10.53%	36.8%	21.1%				57.89%	
28						7.7%		7.7%		15.38%	7.7%				7.69%			7.7%	7.69%	69.2%					69.23%	
31						12.5%				12.50%						12.5%			12.50%	37.5%	37.5%	7.7%			75.00%	
32						15.4%				15.38%	23.1%				23.08%					38.5%	15.4%	7.7%			61.54%	
34						11.1%		11.1%		22.22%										55.8%	22.2%				77.78%	
37						35.0%				35.00%	5.0%				5.00%	5.0%		5.00%	50.0%	5.0%					55.00%	
39						15.4%		7.7%		23.08%	23.1%				23.08%					46.2%		7.7%			53.85%	
40			3.4%		3.45%	3.4%	3.4%	3.4%	3.4%	13.79%	3.4%				3.45%	3.4%	3.4%	6.90%	51.7%	17.2%	3.4%			72.41%		
42						14.3%	7.1%			21.43%		7.1%			7.14%			7.14%	35.7%	28.6%					64.29%	
43						2.6%		2.6%		5.26%		2.6%		2.6%	5.26%					42.1%	47.4%				89.47%	
44							6.3%		6.3%	12.50%										68.8%	12.5%	6.3%			87.50%	
45						4.8%				4.76%	4.8%	4.8%			9.52%	4.8%		4.76%	52.4%	23.8%	4.8%				80.95%	
47						7.7%	3.8%	3.8%		15.38%	3.8%	7.7%	3.8%	3.8%	19.23%				46.2%	15.4%	3.8%				65.38%	
50										29.41%	11.8%				11.76%					47.1%	5.9%				52.94%	
51			5.9%		5.88%	29.4%				3.85%		3.8%	3.8%		7.69%					50.0%	38.5%				88.46%	
52						3.3%	3.33%	10.0%		10.0%	20.00%	6.7%	3.3%		10.00%			3.3%	3.33%	40.0%	13.3%	10.0%			63.33%	
53						26.3%	5.3%			31.58%	10.5%				10.53%					15.8%	36.8%	5.3%			57.89%	
54						50.0%	50.00%								50.00%											
55						4.8%				4.76%	14.3%				14.29%	4.8%	9.5%		14.29%	38.1%	19.0%	9.5%			66.67%	
56						4.8%	14.3%			19.05%	4.8%				4.76%					42.9%	23.8%	9.5%			76.19%	
57						7.1%		21.4%		28.57%	7.1%		14.3%		21.43%	7.1%		7.14%	14.3%			28.6%			42.86%	
58						4.5%				4.55%	18.2%	22.7%	4.5%		45.45%					22.7%	27.3%				50.00%	
59						15.0%				15.00%	30.0%	5.0%			35.00%	5.0%		5.0%	10.00%	25.0%	10.0%	5.0%			40.00%	
60		1.7%			1.72%	31.0%	3.4%			34.48%	20.7%				20.69%	1.7%			1.72%	37.9%	3.4%				41.38%	
61				4.8%	4.76%	9.5%	4.8%	4.8%		19.05%	23.8%		4.8%	4.8%	33.33%	4.8%			4.76%	9.5%	23.8%	4.8%			38.10%	
62						14.3%	4.8%			19.05%	33.3%				33.33%	4.8%	9.5%	4.8%	19.05%	19.0%	9.5%				28.57%	

Sector 3

Clasificación	Tipo A					Tipo B					Tipo C					Tipo D				Tipo D					
Material	Concreto Armado					Ladrillo Con Columna					Ladrillo Con Columna / Sin Columna					Ladrillo Sin Columna				Adobe					
Estado	Bueno-Muy Bueno					Bueno-Muy Bueno					Regular-Malo			Bueno		Regular-Malo				Regular-Malo					
Manzana	Usos	C.	Q.	T.	E.	Total	C.	Q.	T.	E.	Total	C.	Q.	T.	E.	Total	C.	Q.	T.	Total	C.	Q.	T.	E.	Total
3				25.0%	25.00%							50.0%				50.00%					25.0%				25.00%
4				30.0%	30.00%							50.0%				50.00%					20.0%				20.00%
6			10.0%	20.0%	30.00%	20.0%		10.0%		30.00%		10.0%		10.0%	20.00%						10.0%		10.0%		20.00%
8			4.3%		4.35%	8.7%				8.70%	30.4%		8.7%			39.13%		4.3%	4.3%	8.70%	21.7%	8.7%	8.7%		39.13%
9				6.3%	6.25%	31.3%				31.25%	12.5%				12.50%		12.5%		4.3%	4.3%	12.50%	25.0%	12.5%		37.50%
11						68.8%		12.5%		31.25%	6.3%		12.5%		18.75%										
13						18.8%				18.75%	25.0%				25.00%						50.0%	6.3%			56.25%
15				20.0%	20.00%	40.0%		20.0%		60.00%													20.0%		20.00%
19				5.6%	5.56%	27.8%	5.6%			33.33%	16.7%				16.67%						33.3%		11.1%		44.44%
20				9.5%	9.52%	9.5%		9.5%	4.8%	23.81%	4.8%	4.8%	4.8%		14.29%		4.8%		4.76%	38.1%		9.5%		47.62%	
21						3.8%			7.7%	11.54%	11.5%	3.8%			15.38%					57.7%	11.5%	3.8%		73.08%	
23						12.5%				12.50%	25.0%			8.3%	33.33%					41.7%	4.2%	8.3%		54.17%	
24				14.8%	14.81%	33.3%				33.33%			7.4%		7.41%					33.3%	3.7%	7.4%		44.44%	
25			4.2%	4.2%	8.33%	4.2%	4.2%	8.3%		16.67%										41.7%	4.2%	29.2%		75.00%	
27						18.8%				18.75%	12.5%				12.50%					56.3%		12.5%		68.75%	
29	40.0%			10.0%	50.00%	40.0%	10.0%			50.00%															
31			11.1%	11.1%	22.22%							11.1%			11.11%						55.6%		11.1%		66.67%
34																		50.0%	50.00%				50.0%		50.00%
35			7.4%	7.4%	14.81%	40.7%	3.7%	3.7%	3.7%	51.85%										18.5%	3.7%	11.1%		33.33%	
38						11.4%	11.4%	2.9%		25.71%	5.7%				5.71%					54.3%	11.4%	2.9%		68.57%	
39											33.3%				33.33%					55.6%	11.1%			66.67%	
40						44.4%		5.6%		50.00%	16.7%				16.67%					27.8%		5.6%		33.33%	
42											22.2%				22.22%					66.7%		11.1%		77.78%	
44						40.0%				40.00%										60.0%				60.00%	
48						9.1%				9.09%	18.2%				18.18%					72.7%				72.73%	
51						30.8%		7.7%		38.43%	7.7%	7.7%			15.38%	7.7%			7.69%	23.1%		15.4%		38.46%	
53				6.7%	6.67%	13.3%		6.7%		20.00%	26.7%	6.7%	20.0%	6.7%	60.00%	6.7%			6.67%	6.7%				6.67%	
55			6.3%	6.3%	12.50%	6.3%	3.1%	3.1%	3.1%	15.63%			6.3%		6.25%					9.4%	12.5%	43.8%		65.63%	
56				17.4%	17.39%	26.1%	8.7%	4.3%	4.3%	43.48%	4.3%		4.3%		8.70%	4.3%			4.35%	21.7%		4.3%		26.09%	
58			6.7%		6.67%			6.7%		6.67%	13.3%	6.7%			20.00%					33.3%		33.3%		66.67%	
60				7.7%	7.69%	61.5%		7.7%	7.7%	76.92%	7.7%				7.69%					7.7%				7.69%	
64	3.0%			3.0%	6.06%	27.3%	6.1%	9.1%		42.42%	3.0%				3.03%					24.2%	9.1%	15.2%		48.48%	
65						50.0%			10.0%	50.00%										40.0%				40.00%	
67						94.7%		5.3%		100.00%															
69				6.7%	6.67%	86.7%			6.7%	93.3%															
70						17.2%	10.3%	3.4%		31.03%	6.9%		3.4%		10.34%	6.9%			6.90%	41.4%	10.3%			51.72%	
71						20.6%				20.59%	29.4%	2.9%	2.9%		35.29%	5.9%		2.9%	8.82%	23.5%	11.8%			35.29%	
72						18.8%				18.75%	37.5%	6.3%		12.5%	56.25%	18.8%			18.75%			6.3%		6.25%	
74						42.1%				42.11%	36.8%	5.3%	15.8%		57.89%										
76						12.5%	8.3%	12.5%	8.3%	41.67%	16.7%	20.8%	8.3%		45.83%				4.17%	4.2%	4.2%			8.33%	
78			100.0%		100.00%																				
80	0.8%		1.5%	4.4%	6.8%	24.0%	2.5%	3.4%	1.5%	31.45%	12.7%	1.9%	3.2%	0.6%	18.34%	1.9%	0.3%	0.4%	2.62%	28.4%	4.4%	8.0%		40.83%	

Cantidad de Edificaciones por manzana en cada sector

Sector 1

Clasificación	Tipo A	Tipo B	Tipo C		Tipo D	
Material	Concreto Armado	Ladrillo Con Columna	Ladrillo Con Columna	Ladrillo Sin Columna	Ladrillo Sin Columna	Adobe
Estado Manzana	Bueno-Muy Bueno	Bueno-Muy Bueno	Regular-Malo	Bueno	Regular-Malo	Regular-Malo
1	1	13	0	1	1	1
2	1	6	5	0	0	1
3	2	10	8	0	0	0
4	0	19	11	0	0	0
8	2	1	3	0	1	6
11	4	6	4	0	0	0
13	0	7	1	1	5	1
15	2	4	4	0	1	3
19	4	8	4	1	0	0
23	1	3	4	0	2	8
25	1	2	3	3	2	3
26	0	1	1	0	0	9
27	0	5	1	1	1	8
29	0	5	4	1	1	6
30	2	3	4	0	0	12
32	1	8	1	0	0	1
33	0	3	2	1	1	8
34	0	9	16	0	1	6
39	0	37	0	0	0	0
40	1	17	1	0	0	12
41	0	7	3	2	3	4
43	1	4	1	1	0	6
45	6	13	3	0	0	0
48	2	14	0	0	2	0
51	0	3	1	0	1	1
53	0	4	6	0	1	5
56	0	2	0	0	0	0
57	1	11	2	0	4	0
61	1	15	1	3	1	4
63	1	8	2	1	0	8
64	2	20	2	2	0	0
65	1	0	0	0	0	0
Total	37	268	98	18	28	113

Sector 2

Clasificación		Tipo A	Tipo B	Tipo C		Tipo D	
Material	Estado	Concreto Armado	Ladrillo Con Columna	Ladrillo Con Columna	Ladrillo Sin Columna	Ladrillo Sin Columna	Adobe
Manzana		Bueno-Muy Bueno	Bueno-Muy Bueno	Regular-Malo	Bueno	Regular-Malo	Regular-Malo
1		0	2	4	0	3	6
2		0	2	0	0	2	7
3		0	0	1	0	3	8
4		2	3	3	0	0	6
5		0	0	4	0	2	8
6		1	1	2	0	0	6
7		0	1	8	0	5	2
9		1	3	3	0	0	9
10		0	2	1	0	0	9
11		0	1	3	0	0	4
12		0	2	6	2	3	3
14		0	1	5	0	1	11
16		0	3	1	0	0	8
17		0	2	1	3	7	9
19		0	3	5	3	3	0
20		0	5	1	0	0	6
23		1	4	3	3	1	13
26		0	1	1	1	0	8
27		0	4	2	0	2	11
28		0	2	1	0	1	9
31		0	1	0	0	1	6
32		0	2	2	1	0	8
34		0	2	0	0	0	7
37		0	7	0	1	1	11
39		0	3	3	0	0	7
40		1	4	1	0	2	21
42		0	3	0	1	1	9
43		0	2	2	0	0	34
44		0	2	0	0	0	14
45		0	1	0	2	1	17
47		0	4	4	1	0	17
50		1	5	1	1	0	9
51		0	1	1	1	0	23
52		1	6	3	0	1	19
53		0	6	1	1	0	11
54		1	0	0	1	0	0
55		0	1	3	0	3	14
56		0	4	0	1	0	16
57		0	4	1	2	1	6
58		0	1	8	2	0	11
59		0	3	5	2	2	8
60		1	20	12	0	1	24
61		1	4	7	0	1	8
62		0	4	7	0	4	6
Total		11	132	116	29	52	449

Sector 3

Clasificación		Tipo A	Tipo B	Tipo C		Tipo D	
Material	Estado	Concreto Armado	Ladrillo Con Columna	Ladrillo Con Columna	Ladrillo Sin Columna	Ladrillo Sin Columna	Adobe
Manzana		Bueno-Muy Bueno	Bueno-Muy Bueno	Regular-Malo	Bueno	Regular-Malo	Regular-Malo
3		2	2	3	0	1	10
4		2	0	4	0	0	2
6		3	0	5	0	0	2
8		3	3	1	1	0	2
9		1	2	4	5	2	9
11		1	5	2	0	2	6
13		0	13	3	0	0	0
15		0	3	4	0	0	9
19		1	3	0	0	0	1
20		1	6	1	2	0	8
21		2	5	3	0	1	10
23		0	3	4	0	0	19
24		0	3	8	0	0	13
25		4	9	2	0	0	12
27		2	4	0	0	0	18
29		0	3	2	0	0	11
31		5	5	0	0	0	0
34		2	0	0	1	0	6
35		0	0	0	0	1	1
38		4	14	0	0	0	9
39		0	9	1	1	0	24
40		0	0	0	3	0	6
42		0	9	1	2	0	6
44		0	0	2	0	0	7
48		0	2	0	0	0	3
51		0	1	0	2	0	8
53		0	5	2	0	1	5
55		1	3	9	0	1	1
56		4	5	2	0	0	21
58		4	10	2	0	1	6
60		1	1	3	0	0	10
64		1	10	1	0	0	1
65		2	14	1	0	0	16
67		0	6	0	0	0	4
69		0	19	0	0	0	0
70		1	14	0	0	0	0
71		0	9	3	0	2	15
72		0	7	8	4	3	12
74		0	3	9	0	3	1
76		0	8	10	1	0	0
78		0	10	11	0	1	2
80		2	0	0	0	0	0
Total		49	228	111	22	19	296

Porcentaje de Edificaciones por manzana en cada sector

Sector 1

Clasificación	Tipo A	Tipo B	Tipo C		Tipo D	
Material	Concreto Armado	Ladrillo Con Columna	Ladrillo Con Columna	Ladrillo Sin Columna	Ladrillo Sin Columna	Adobe
Estado Manzana	Bueno-Muy Bueno	Bueno-Muy Bueno	Regular-Malo	Bueno	Regular-Malo	Regular-Malo
1	5.88%	76.47%	0.00%	5.88%	5.88%	5.88%
2	7.69%	46.15%	38.46%	0.00%	0.00%	7.69%
3	10.00%	50.00%	40.00%	0.00%	0.00%	0.00%
4	0.00%	63.33%	36.67%	0.00%	0.00%	0.00%
8	15.38%	7.69%	23.08%	0.00%	7.69%	46.15%
11	28.57%	42.86%	28.57%	0.00%	0.00%	0.00%
13	0.00%	46.67%	6.67%	6.67%	33.33%	6.67%
15	14.29%	28.57%	28.57%	0.00%	7.14%	21.43%
19	23.53%	47.06%	23.53%	5.88%	0.00%	0.00%
23	5.56%	16.67%	22.22%	0.00%	11.11%	44.44%
25	7.14%	14.29%	21.43%	21.43%	14.29%	21.43%
26	0.00%	9.09%	9.09%	0.00%	0.00%	81.82%
27	0.00%	31.25%	6.25%	6.25%	6.25%	50.00%
29	0.00%	29.41%	23.53%	5.88%	5.88%	35.29%
30	9.52%	14.29%	19.05%	0.00%	0.00%	57.14%
32	9.09%	72.73%	9.09%	0.00%	0.00%	9.09%
33	0.00%	20.00%	13.33%	6.67%	6.67%	53.33%
34	0.00%	28.13%	50.00%	0.00%	3.13%	18.75%
39	0.00%	100.00%	0.00%	0.00%	0.00%	0.00%
40	3.23%	54.84%	3.23%	0.00%	0.00%	38.71%
41	0.00%	36.84%	15.79%	10.53%	15.79%	21.05%
43	7.69%	30.77%	7.69%	7.69%	0.00%	46.15%
45	27.27%	59.09%	13.64%	0.00%	0.00%	0.00%
48	11.11%	77.78%	0.00%	0.00%	11.11%	0.00%
51	0.00%	50.00%	16.67%	0.00%	16.67%	16.67%
53	0.00%	25.00%	37.50%	0.00%	6.25%	31.25%
56	0.00%	100.00%	0.00%	0.00%	0.00%	0.00%
57	5.56%	61.11%	11.11%	0.00%	22.22%	0.00%
61	4.00%	60.00%	4.00%	12.00%	4.00%	16.00%
63	5.00%	40.00%	10.00%	5.00%	0.00%	40.00%
64	7.69%	76.92%	7.69%	7.69%	0.00%	0.00%
65	100.00%	0.00%	0.00%	0.00%	0.00%	0.00%

Sector 2

Clasificación	Tipo A	Tipo B	Tipo C		Tipo D	
Material	Concreto Armado	Ladrillo Con Columna	Ladrillo Con Columna	Ladrillo Sin Columna	Ladrillo Sin Columna	Adobe
Estado Manzana	Bueno-Muy Bueno	Bueno-Muy Bueno	Regular-Malo	Bueno	Regular-Malo	Regular-Malo
1	0.00%	13.33%	26.67%	0.00%	20.00%	40.00%
2	0.00%	18.18%	18.18%	0.00%	18.18%	63.64%
3	0.00%	0.00%	8.33%	0.00%	25.00%	66.67%
4	14.29%	21.43%	21.43%	0.00%	0.00%	42.86%
5	0.00%	0.00%	28.57%	0.00%	14.29%	57.14%
6	10.00%	10.00%	20.00%	0.00%	0.00%	60.00%
7	0.00%	6.25%	50.00%	0.00%	31.25%	12.50%
9	6.25%	18.75%	18.75%	0.00%	0.00%	56.25%
10	0.00%	16.67%	8.33%	0.00%	0.00%	75.00%
11	0.00%	12.50%	37.50%	0.00%	0.00%	50.00%
12	0.00%	12.50%	37.50%	12.50%	18.75%	18.75%
14	0.00%	5.56%	27.78%	0.00%	5.56%	61.11%
16	0.00%	25.00%	8.33%	0.00%	0.00%	66.67%
17	0.00%	9.09%	4.55%	13.64%	31.82%	40.91%
19	0.00%	21.43%	35.71%	21.43%	21.43%	0.00%
20	0.00%	41.67%	8.33%	0.00%	0.00%	50.00%
23	4.00%	16.00%	12.00%	12.00%	4.00%	52.00%
26	0.00%	9.09%	9.09%	9.09%	0.00%	72.73%
27	0.00%	21.05%	10.53%	0.00%	10.53%	57.89%
28	0.00%	15.38%	7.69%	0.00%	7.69%	69.23%
31	0.00%	12.50%	0.00%	0.00%	12.50%	75.00%
32	0.00%	15.38%	15.38%	7.69%	0.00%	61.54%
34	0.00%	22.22%	0.00%	0.00%	0.00%	77.78%
37	0.00%	35.00%	0.00%	5.00%	5.00%	55.00%
39	0.00%	23.08%	23.08%	0.00%	0.00%	53.85%
40	3.45%	13.79%	3.45%	0.00%	6.90%	72.41%
42	0.00%	21.43%	0.00%	7.14%	7.14%	64.29%
43	0.00%	5.26%	5.26%	0.00%	0.00%	89.47%
44	0.00%	12.50%	0.00%	0.00%	0.00%	87.50%
45	0.00%	4.76%	0.00%	9.52%	4.76%	80.95%
47	0.00%	15.38%	15.38%	3.85%	0.00%	65.38%
50	5.88%	29.41%	5.88%	5.88%	0.00%	52.94%
51	0.00%	3.85%	3.85%	3.85%	0.00%	88.46%
52	3.33%	20.00%	10.00%	0.00%	3.33%	63.33%
53	0.00%	31.58%	5.26%	5.26%	0.00%	57.89%
54	50.00%	0.00%	0.00%	50.00%	0.00%	0.00%
55	0.00%	4.76%	14.29%	0.00%	14.29%	66.67%
56	0.00%	19.05%	0.00%	4.76%	0.00%	76.19%
57	0.00%	28.57%	7.14%	14.29%	7.14%	42.86%
58	0.00%	4.55%	36.36%	9.09%	0.00%	50.00%
59	0.00%	15.00%	25.00%	10.00%	10.00%	40.00%
60	1.72%	34.48%	20.69%	0.00%	1.72%	41.38%
61	4.76%	19.05%	33.33%	0.00%	4.76%	38.10%
62	0.00%	19.05%	33.33%	0.00%	19.05%	28.57%

Sector 3

Clasificación	Tipo A	Tipo B	Tipo C		Tipo D	
Material	Concreto Armado	Ladrillo Con Columna	Ladrillo Con Columna	Ladrillo Sin Columna	Ladrillo Sin Columna	Adobe
Estado Manzana	Bueno-Muy Bueno	Bueno-Muy Bueno	Regular-Malo	Bueno	Regular-Malo	Regular-Malo
3	11.11%	11.11%	16.67%	0.00%	5.56%	55.56%
4	25.00%	0.00%	50.00%	0.00%	0.00%	25.00%
6	30.00%	0.00%	50.00%	0.00%	0.00%	20.00%
8	30.00%	30.00%	10.00%	10.00%	0.00%	20.00%
9	4.35%	8.70%	17.39%	21.74%	8.70%	39.13%
11	6.25%	31.25%	12.50%	0.00%	12.50%	37.50%
13	0.00%	81.25%	18.75%	0.00%	0.00%	0.00%
15	0.00%	18.75%	25.00%	0.00%	0.00%	56.25%
19	20.00%	60.00%	0.00%	0.00%	0.00%	20.00%
20	5.56%	33.33%	5.56%	11.11%	0.00%	44.44%
21	9.52%	23.81%	14.29%	0.00%	4.76%	47.62%
23	0.00%	11.54%	15.38%	0.00%	0.00%	73.08%
24	0.00%	12.50%	33.33%	0.00%	0.00%	54.17%
25	14.81%	33.33%	7.41%	0.00%	0.00%	44.44%
27	8.33%	16.67%	0.00%	0.00%	0.00%	75.00%
29	0.00%	18.75%	12.50%	0.00%	0.00%	68.75%
31	50.00%	50.00%	0.00%	0.00%	0.00%	0.00%
34	22.22%	0.00%	0.00%	11.11%	0.00%	66.67%
35	0.00%	0.00%	0.00%	0.00%	50.00%	50.00%
38	14.81%	51.85%	0.00%	0.00%	0.00%	33.33%
39	0.00%	25.71%	2.86%	2.86%	0.00%	68.57%
40	0.00%	0.00%	0.00%	33.33%	0.00%	66.67%
42	0.00%	50.00%	5.56%	11.11%	0.00%	33.33%
44	0.00%	0.00%	22.22%	0.00%	0.00%	77.78%
48	0.00%	40.00%	0.00%	0.00%	0.00%	60.00%
51	0.00%	9.09%	0.00%	18.18%	0.00%	72.73%
53	0.00%	38.46%	15.38%	0.00%	7.69%	38.46%
55	6.67%	20.00%	60.00%	0.00%	6.67%	6.67%
56	12.50%	15.63%	6.25%	0.00%	0.00%	65.63%
58	17.39%	43.48%	8.70%	0.00%	4.35%	26.09%
60	6.67%	6.67%	20.00%	0.00%	0.00%	66.67%
64	7.69%	76.92%	7.69%	0.00%	0.00%	7.69%
65	6.08%	42.42%	3.03%	0.00%	0.00%	48.48%
67	0.00%	60.00%	0.00%	0.00%	0.00%	40.00%
69	0.00%	100.00%	0.00%	0.00%	0.00%	0.00%
70	6.67%	93.33%	0.00%	0.00%	0.00%	0.00%
71	0.00%	31.03%	10.34%	0.00%	6.90%	51.72%
72	0.00%	20.59%	23.53%	11.76%	8.82%	35.29%
74	0.00%	18.75%	56.25%	0.00%	18.75%	6.25%
76	0.00%	42.11%	52.63%	5.26%	0.00%	0.00%
78	0.00%	41.67%	45.83%	0.00%	4.17%	8.33%
80	100.00%	0.00%	0.00%	0.00%	0.00%	0.00%

Sector 1

Clasificación		Tipo A	Tipo B	Tipo C	Tipo D	Tipo de mayor
Manzana	Estado	Bueno-Muy Bueno	Bueno-Muy Bueno	Regular-Malo	Regular-Malo	Ocurrencia
	1		5.88%	76.47%	5.88%	11.76%
2		7.69%	46.15%	38.46%	7.69%	B
3		10.00%	50.00%	40.00%	0.00%	B
4		0.00%	63.33%	36.67%	0.00%	B
8		15.38%	7.69%	23.08%	53.85%	D
11		28.57%	42.86%	28.57%	0.00%	B
13		0.00%	46.67%	13.33%	40.00%	B
15		14.29%	28.57%	28.57%	28.57%	D,C
19		23.53%	47.06%	29.41%	0.00%	B
23		5.56%	16.67%	22.22%	55.56%	D
25		7.14%	14.29%	42.86%	35.71%	C
26		0.00%	9.09%	9.09%	81.82%	D
27		0.00%	31.25%	12.50%	56.25%	D
29		0.00%	29.41%	29.41%	41.18%	D
30		9.52%	14.29%	19.05%	57.14%	D
32		9.09%	72.73%	9.09%	9.09%	B
33		0.00%	20.00%	20.00%	60.00%	D
34		0.00%	28.13%	50.00%	21.88%	C
39		0.00%	100.00%	0.00%	0.00%	B
40		3.23%	54.84%	3.23%	38.71%	B
41		0.00%	36.84%	26.32%	36.84%	D,B
43		7.69%	30.77%	15.38%	46.15%	D
45		27.27%	59.09%	13.64%	0.00%	B
48		11.11%	77.78%	0.00%	11.11%	B
51		0.00%	50.00%	16.67%	33.33%	B
53		0.00%	25.00%	37.50%	37.50%	D,C
56		0.00%	100.00%	0.00%	0.00%	B
57		5.56%	61.11%	11.11%	22.22%	B
61		4.00%	60.00%	16.00%	20.00%	B
63		5.00%	40.00%	15.00%	40.00%	D,B
64		7.69%	76.92%	15.38%	0.00%	B
65		100.00%	0.00%	0.00%	0.00%	A

Sector 2

Manzana	Estado	Clasificación	Tipo A	Tipo B	Tipo C	Tipo D	Tipo de mayor
			Bueno-Muy Bueno	Bueno-Muy Bueno	Regular-Malo	Regular-Malo	Ocurrencia
1			0.00%	13.33%	26.67%	60.00%	D
2			0.00%	18.18%	0.00%	81.82%	D
3			0.00%	0.00%	8.33%	91.67%	D
4			14.29%	21.43%	21.43%	42.86%	D
5			0.00%	0.00%	28.57%	71.43%	D
6			10.00%	10.00%	20.00%	60.00%	D
7			0.00%	6.25%	50.00%	43.75%	C
9			6.25%	18.75%	18.75%	56.25%	D
10			0.00%	16.67%	8.33%	75.00%	D
11			0.00%	12.50%	37.50%	50.00%	D
12			0.00%	12.50%	50.00%	37.50%	C
14			0.00%	5.56%	27.78%	66.67%	D
16			0.00%	25.00%	8.33%	66.67%	D
17			0.00%	9.09%	18.18%	72.73%	D
19			0.00%	21.43%	57.14%	21.43%	C
20			0.00%	41.67%	8.33%	50.00%	D
23			4.00%	16.00%	24.00%	56.00%	D
26			0.00%	9.09%	18.18%	72.73%	D
27			0.00%	21.05%	10.53%	68.42%	D
28			0.00%	15.38%	7.69%	76.92%	D
31			0.00%	12.50%	0.00%	87.50%	D
32			0.00%	15.38%	23.08%	61.54%	D
34			0.00%	22.22%	0.00%	77.78%	D
37			0.00%	35.00%	5.00%	60.00%	D
39			0.00%	23.08%	23.08%	53.85%	D
40			3.45%	13.79%	3.45%	79.31%	D
42			0.00%	21.43%	7.14%	71.43%	D
43			0.00%	5.26%	5.26%	89.47%	D
44			0.00%	12.50%	0.00%	87.50%	D
45			0.00%	4.76%	9.52%	85.71%	D
47			0.00%	15.38%	19.23%	65.38%	D
50			5.88%	29.41%	11.76%	52.94%	D
51			0.00%	3.85%	7.69%	88.46%	D
52			3.33%	20.00%	10.00%	66.67%	D
53			0.00%	31.58%	10.53%	57.89%	D
54			50.00%	0.00%	50.00%	0.00%	C,A
55			0.00%	4.76%	14.29%	80.95%	D
56			0.00%	19.05%	4.76%	76.19%	D
57			0.00%	28.57%	21.43%	50.00%	D
58			0.00%	4.55%	45.45%	50.00%	D
59			0.00%	15.00%	35.00%	50.00%	D
60			1.72%	34.48%	20.69%	43.10%	D
61			4.76%	19.05%	33.33%	42.86%	D
62			0.00%	19.05%	33.33%	47.62%	D

Sector 3

Clasificación	Tipo A	Tipo B	Tipo C	Tipo D	Tipo de mayor
Estado Manzana	Bueno-Muy Bueno	Bueno-Muy Bueno	Regular-Malo	Regular-Malo	Ocurrencia
3	11.11%	11.11%	16.67%	61.11%	D
4	25.00%	0.00%	50.00%	25.00%	C
6	30.00%	0.00%	50.00%	20.00%	C
8	30.00%	30.00%	20.00%	20.00%	B,A
9	4.35%	8.70%	39.13%	47.83%	D
11	6.25%	31.25%	12.50%	50.00%	D
13	0.00%	81.25%	18.75%	0.00%	B
15	0.00%	18.75%	25.00%	56.25%	D
19	20.00%	60.00%	0.00%	20.00%	B
20	5.56%	33.33%	16.67%	44.44%	D
21	9.52%	23.81%	14.29%	52.38%	D
23	0.00%	11.54%	15.38%	73.08%	D
24	0.00%	12.50%	33.33%	54.17%	D
25	14.81%	33.33%	7.41%	44.44%	D
27	8.33%	16.67%	0.00%	75.00%	D
29	0.00%	18.75%	12.50%	68.75%	D
31	50.00%	50.00%	0.00%	0.00%	B,A
34	22.22%	0.00%	11.11%	66.67%	D
35	0.00%	0.00%	0.00%	100.00%	D
38	14.81%	51.85%	0.00%	33.33%	B
39	0.00%	25.71%	5.71%	68.57%	D
40	0.00%	0.00%	33.33%	66.67%	D
42	0.00%	50.00%	16.67%	33.33%	B
44	0.00%	0.00%	22.22%	77.78%	D
48	0.00%	40.00%	0.00%	60.00%	D
51	0.00%	9.09%	18.18%	72.73%	D
53	0.00%	38.46%	15.38%	46.15%	D
55	6.67%	20.00%	60.00%	13.33%	C
56	12.50%	15.63%	6.25%	65.63%	D
58	17.39%	43.48%	8.70%	30.43%	B
60	6.67%	6.67%	20.00%	66.67%	D
64	7.69%	76.92%	7.69%	7.69%	B
65	6.06%	42.42%	3.03%	48.48%	D
67	0.00%	60.00%	0.00%	40.00%	B
69	0.00%	100.00%	0.00%	0.00%	B
70	6.67%	93.33%	0.00%	0.00%	B
71	0.00%	31.03%	10.34%	58.62%	D
72	0.00%	20.59%	35.29%	44.12%	D
74	0.00%	18.75%	56.25%	25.00%	C
76	0.00%	42.11%	57.89%	0.00%	C
78	0.00%	41.67%	45.83%	12.50%	C
80	100.00%	0.00%	0.00%	0.00%	A

Anexo III

**Planos de configuración estructural de
edificaciones tipo A, B y C**

Muros de Edificación Tipo B



Lámina : B-1

Escala : 1/100

Estudio de Vulnerabilidad Sísmica de Edificaciones del Distrito de Barranco

Ubicación de la Edificación: Av. Pedro de Osma 203- A

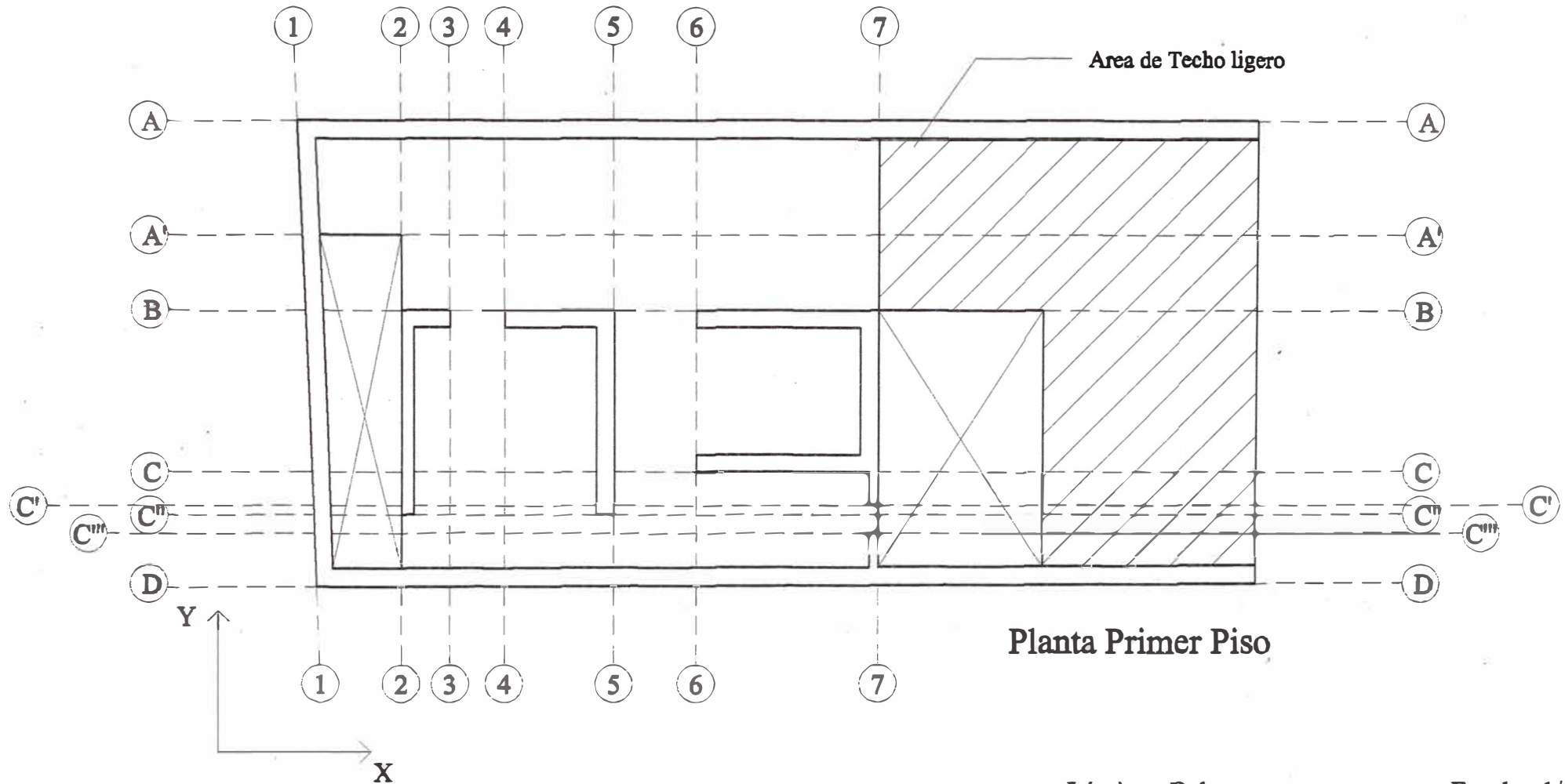

CISMID - Universidad Nacional de Ingeniería - FIC



Autor: Bach. Ing. Carlos D. Vizurraga Torres

Muros de Edificación Tipo B



Lámina : B-2

Escala : 1/100

Estudio de Vulnerabilidad Sísmica de Edificaciones del Distrito de Barranco

Ubicación de la Edificación: Av. Pedro de Osma 203- A

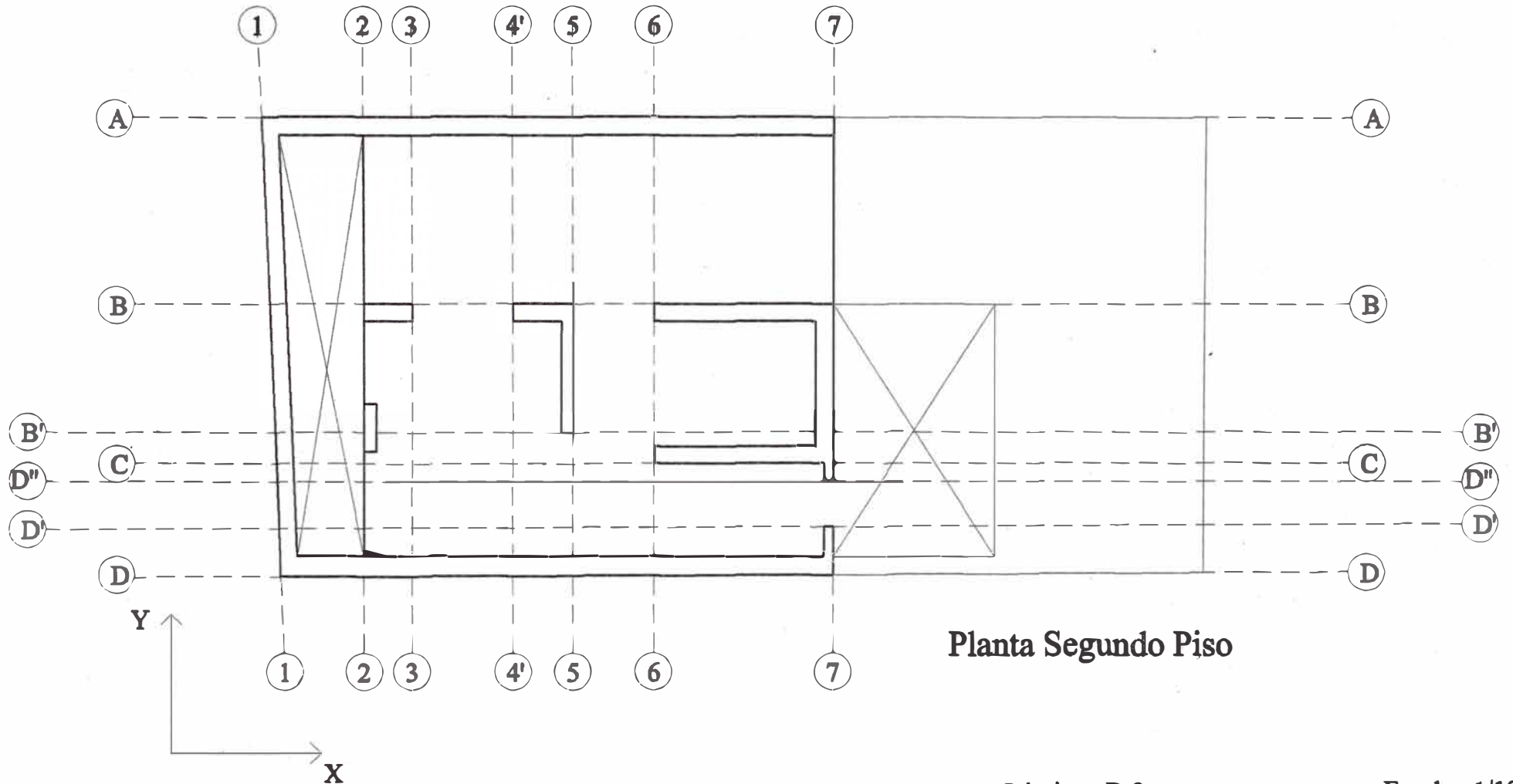

CISMID - Universidad Nacional de Ingeniería - FIC



Autor: Bach. Ing. Carlos D. Vizurraga Torres

Muros de Edificación Tipo B

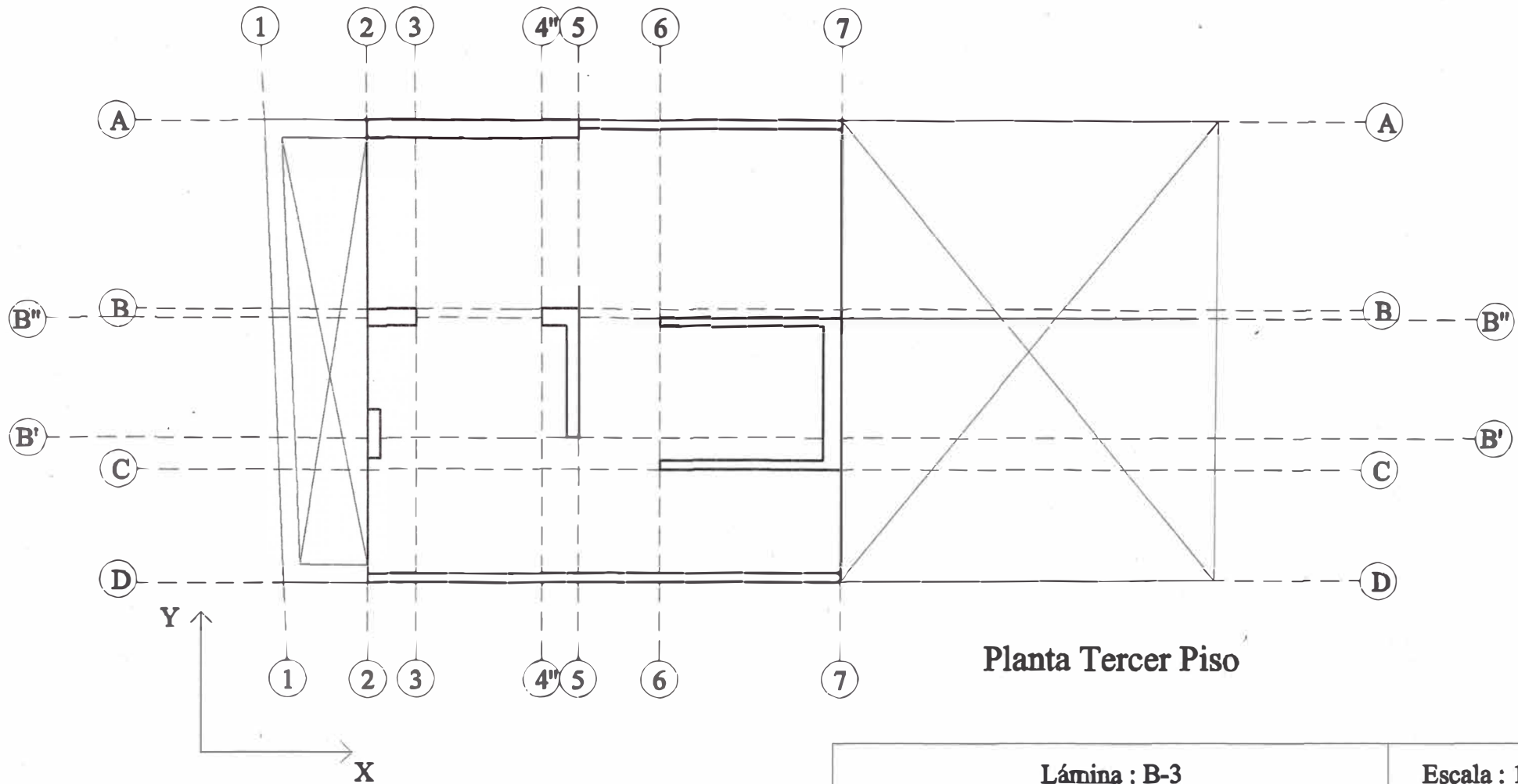

Planta Tercer Piso

Lámina : B-3

Escala : 1/100

Estudio de Vulnerabilidad Sísmica de Edificaciones del Distrito de Barranco

Ubicación de la Edificación: Av. Pedro de Osma 203- A



CISMID - Universidad Nacional de Ingeniería - FIC



Autor: Bach. Ing. Carlos D. Vizurraga Torres

Muros de Edificación Tipo C

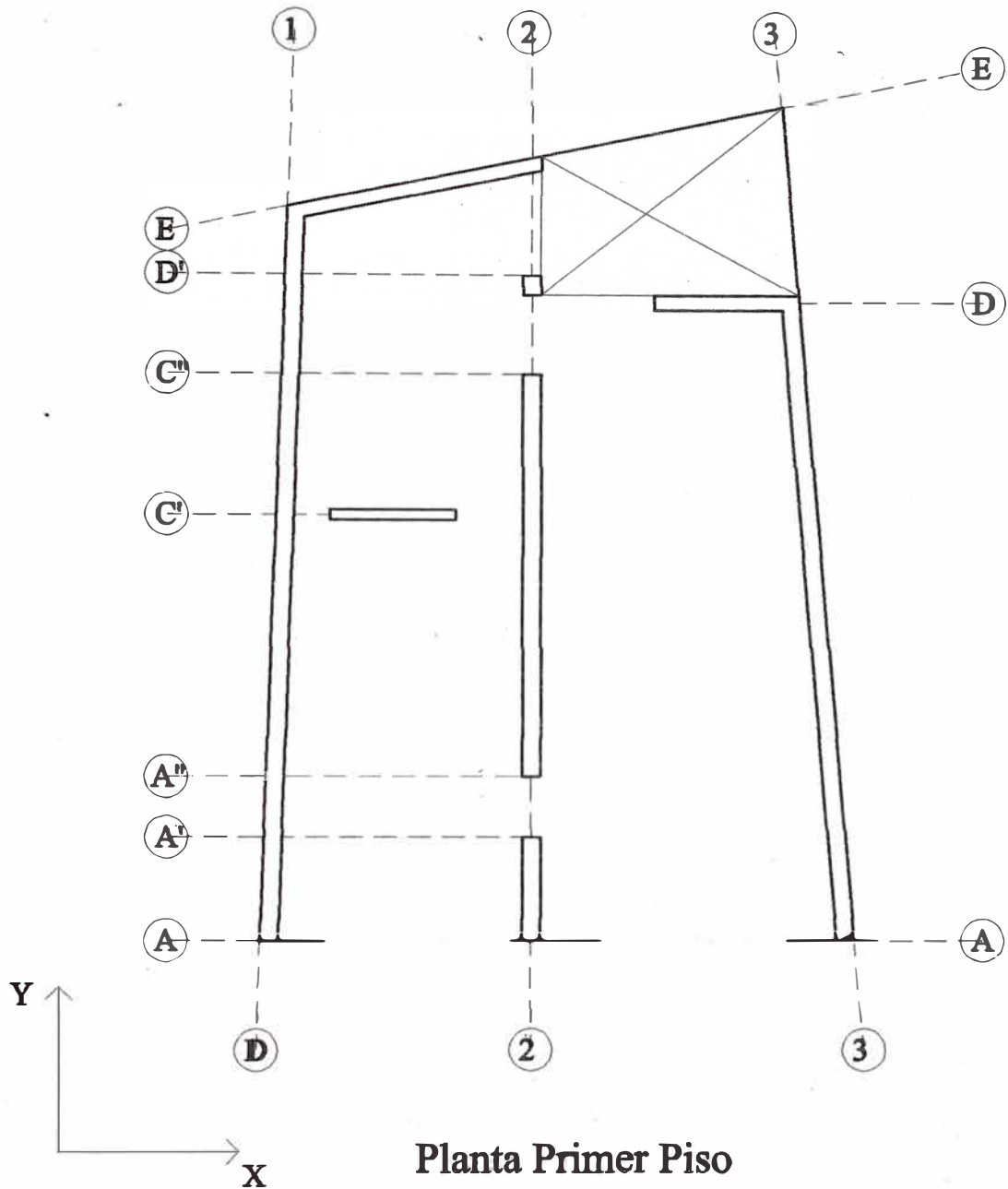

Ubicación de Edif. : Jr Bernardette- Barranco

Estudio de Vulnerabilidad Sísmica de Edificaciones del Distrito de Barranco

CISMID - Universidad Nacional de Ingeniería - FIC

Lámina : C-1

Autor: Bach. Ing. Carlos D. Vizurraga Torres

Escala : 1/100



Muros de Edificación Tipo C

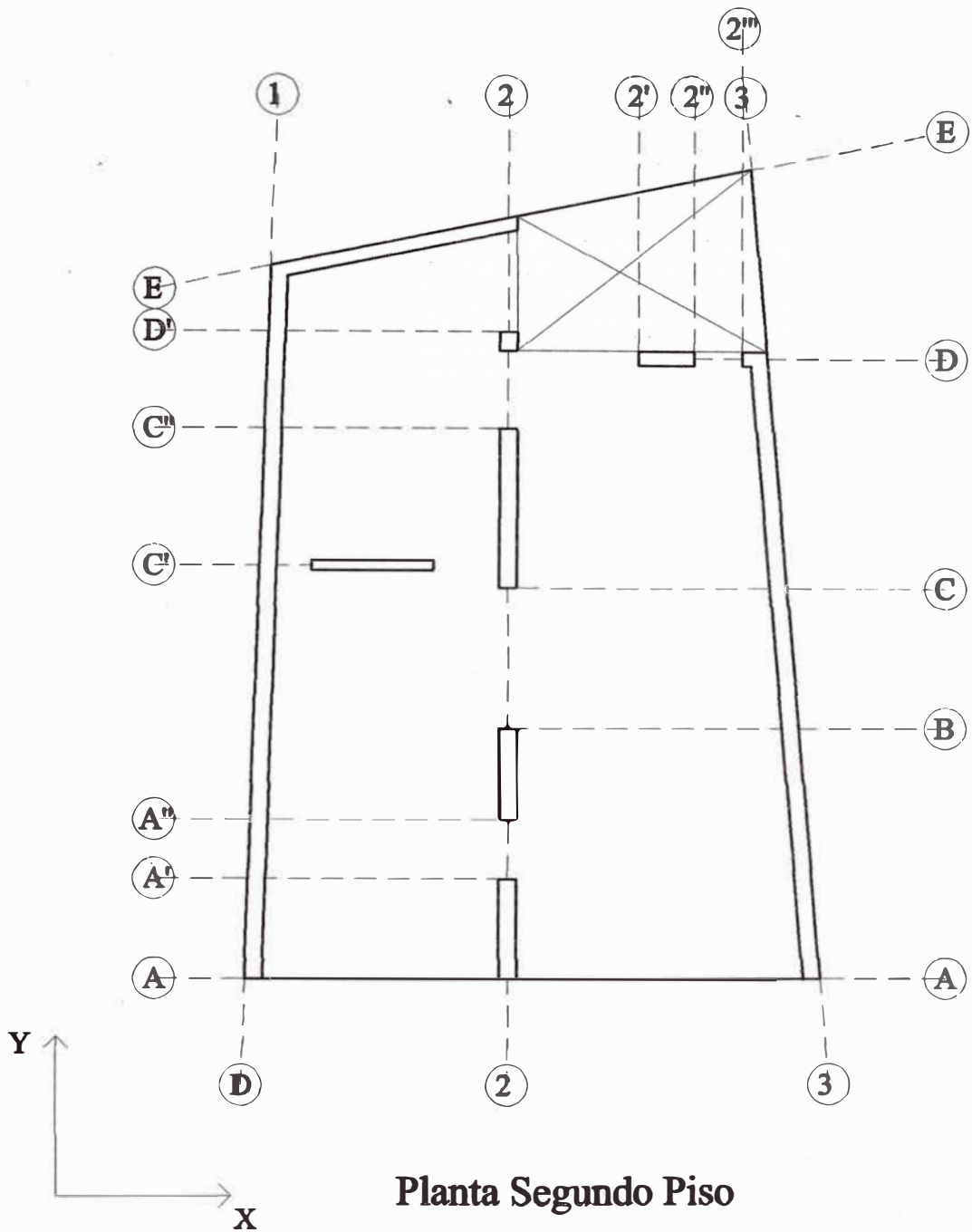

Ubicación de Edif. : Jr Bernardette- Barranco

Estudio de Vulnerabilidad Sísmica de Edificaciones del Distrito de Barranco



CISMID - Universidad Nacional de Ingeniería - FIC



Lámina : C-2

Autor: Bach. Ing. Carlos D. Vizarraga Torres

Escala : 1/100

Muros de Edificación Tipo C

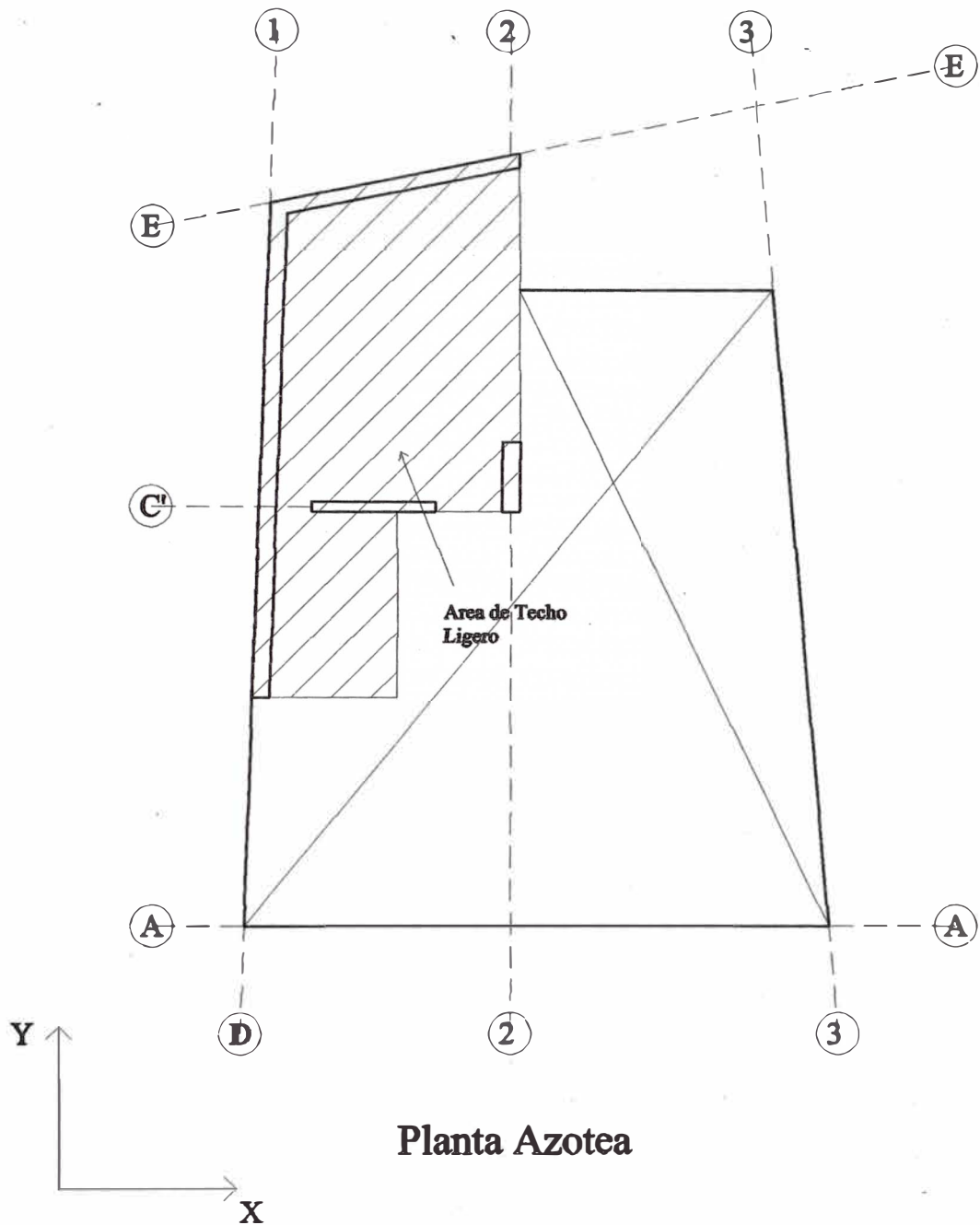

Ubicación de Edif. : Jr Bernardette- Barranco

Estudio de Vulnerabilidad Sísmica de Edificaciones del Distrito de Barranco



CISMID - Universidad Nacional de Ingeniería - FIC



Lámina : C-3

Autor: Bach. Ing. Carlos D. Vizurraga Torres

Escala : 1/100

Anexo IV

Cálculo de rigideces, masas, cortantes y desplazamientos máximos mediante análisis bidimensional para evaluar la densidad de muros y el comportamiento sísmico de las edificaciones tipo.

Cálculo de Rigideces

$E_{\text{albañilería}} = 22.50 \text{ T/cm}^2$	$E_{\text{concreto}} = 210.00 \text{ T/cm}^2$
$t = e - 2\text{cm}$ (2cm de tarrajeo)	$K_{\text{muros}} = \frac{E \cdot t}{[4 \cdot (h/L)^3 + 3 \cdot (h/L)]} \dots\dots\dots(I)$

Edificación Tipo B

(*)Zona con techo ligero desmontable se considerará la rigidez la fórmula (I) dividida entre 4 por no considerar los muros empotrados al techo

(**)Zona de muros sin techo se considerará la rigidez la fórmula (I) dividida entre 4 por no considerar a los muros empotrados al techo, así que no se considerarán como parte de la masa, ni se incluirán en los cálculos del cortante y desplazamiento máximo

Dirección X

1er Nivel

Muro	L (m)	e (cm)	t (cm)	h (m)	L*t(m-cm)	K (T/cm)
A17	9.53	30	28	2.60	266.84	700.24
B23	0.80	28	26	2.60	20.80	3.98
B45	1.80	28	26	2.60	46.80	35.70
B67	3.00	28	26	2.60	78.00	112.42
C	3.00	28	26	2.60	78.00	112.42
(**) D12	1.40	30	28	3.60	39.20	2.08
D27	7.83	30	28	2.60	219.24	551.36
(*) A78	6.22	30	28	2.60	174.16	101.86
(*) D78	6.22	30	28	2.60	174.16	101.86
39.80					1097.20	1518.19

2do Nivel

Muro	L (m)	e (cm)	t (cm)	h (m)	L*t(m-cm)	K (T/cm)
A27	7.86	30	28	2.60	220.08	554.02
(**) A12	1.67	30	28	1.60	46.76	24.64
B23	0.80	28	26	2.60	20.80	3.98
B4'5	1.00	28	26	2.60	26.00	7.49
B67	3.00	28	26	2.60	78.00	112.42
C	3.00	28	26	2.60	78.00	112.42
(**) D12	1.40	30	28	3.60	39.20	2.08
D27	7.83	30	28	2.60	219.24	551.36
26.56					728.08	1368.40

3er Nivel

Muro	L (m)	e (cm)	t (cm)	h (m)	L*t(m-cm)	K (T/cm)
A25	3.50	30	28	2.60	98.00	162.86
A57	4.34	15	13	2.60	56.42	110.08
B23	0.80	28	26	2.60	20.80	3.98
B4'5	0.60	28	26	2.60	15.60	1.73
B67	3.00	15	13	2.60	39.00	56.21
C67	3.00	15	13	2.60	39.00	56.21
C68	7.85	15	13	2.60	102.05	256.81
23.09					370.87	647.87

Dirección Y

1er Nivel

	Muro	L (m)	e (cm)	t (cm)	h (m)	L*t(m-cm)	K (T/cm)
(**)	1A'D	5.73	28	26	2.60	148.98	84.30
	1AA'	1.87	28	26	2.60	48.62	39.20
	2BC''	3.35	20	18	2.60	60.30	96.47
	5BC''	3.35	30	28	2.60	93.80	150.06
	7BC	2.65	30	28	2.60	74.20	93.73
	7CC'	0.55	15	13	2.60	7.15	0.67
	7DC'''	0.85	15	13	2.60	11.05	2.37
		18.35				444.10	466.79

2do Nivel

	Muro	L (m)	e (cm)	t (cm)	h (m)	L*t(m-cm)	K (T/cm)
(**)	1	7.60	28	26	2.60	197.60	123.26
	2	0.80	20	18	2.60	14.40	2.75
	5	2.13	20	18	2.60	38.34	37.03
	7BC	2.65	30	28	2.60	74.20	93.73
	7DC'	0.30	15	13	2.60	3.90	0.11
	7BC	0.80	15	13	2.60	10.40	1.99
		14.28				338.84	258.88

3er Nivel

	Muro	L (m)	e (cm)	t (cm)	h (m)	L*t(m-cm)	K (T/cm)
	7B''C	2.65	30	28	2.60	74.20	93.73
	5	2.13	30	28	2.60	59.64	57.60
		4.78				133.84	151.33

Finalmente:

1er Nivel	$\Sigma K_{x_1} =$	1518.19 T/cm	$\Sigma K_{y_1} =$	466.79 T/cm
2do Nivel	$\Sigma K_{x_2} =$	1368.40 T/cm	$\Sigma K_{y_2} =$	258.88 T/cm
3er Nivel	$\Sigma K_{x_3} =$	647.87 T/cm	$\Sigma K_{y_3} =$	151.33 T/cm

Edificación Tipo C

Dirección X

(*) Su eje en planta tiene Inclinación de 14° con respecto al eje "X" por lo que se multiplicará la rigidez (fórmula (I)) por el coseno y el seno del ángulo, en la dirección respectiva, la contribución a la rigidez en la dirección "Y" se agregará al final de cada cuadro de la siguiente página.

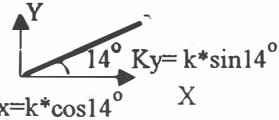

Teniendo en cuenta las salvedades anteriores los resultados finales son los siguientes:

1er Nivel

Muro	L (m)	e (cm)	t (cm)	h (m)	L*t(m-cm)	K (T/cm)
(*) E	3.50	20	18	2.75	63.00	91.44
D	2.03	20	18	2.75	36.54	28.91
C'	1.75	15	13	2.75	22.75	14.45
	7.28				122.29	134.81

$$K_{3x_1} = 44.35 \text{ T/cm (contribución del muro 3 a la rigidez en la dirección "X")}$$

$$\boxed{\Sigma K_{x_1} = 134.81 + 44.35 = 179.16 \text{ T/cm}}$$

2do Nivel

Muro	L (m)	e (cm)	t (cm)	h (m)	L*t(m-cm)	K (T/cm)
(*) E	3.50	20	18	2.70	63.00	94.68
D2'2"	0.80	20	18	2.70	14.40	2.47
D32"	0.46	20	18	2.70	8.28	0.49
C'	1.75	15	13	2.70	22.75	15.14
	6.51				108.43	112.78

$$K_{3x_2} = 45.35 \text{ T/cm (contribución del muro 3 a la rigidez en la dirección "X")}$$

$$\boxed{\Sigma K_{x_2} = 112.78 + 45.35 = 158.13 \text{ T/cm}}$$

3er Nivel

Muro	L (m)	e (cm)	t (cm)	h (m)	L*t(m-cm)	K (T/cm)
(*) E	3.50	20	18	2.70	63.00	94.68
C'	1.75	15	13	2.70	22.75	15.14
	5.25				85.75	109.82

Dirección Y

(**) Su eje en planta tiene Inclinación de 5° con respecto al eje "Y" por lo que se multiplicará la rigidez (fórmula (I)) por el coseno y el seno del ángulo en la dirección respectiva; la contribución a la rigidez en la dirección "X" ya se agregó en los cuadros anteriores.

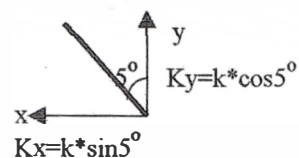

Teniendo en cuenta las salvedades anteriores los resultados finales son los siguientes:

1er Nivel

Muro	L (m)	e (cm)	t (cm)	h (m)	L*t(m-cm)	K (T/cm)
1.00	10.30	25	23	2.75	236.90	590.01
2AA'	1.45	25	23	2.75	33.35	15.69
2A"C"	5.65	25	23	2.75	129.95	269.33
2DD'	0.30	25	23	2.75	6.90	0.17
(**) 3	9.10	25	23	2.75	209.30	506.92
	26.80				616.40	1382.13

$K_{E_y 1} = 22.80$ T/cm (contribución del muro E a la rigidez en la dirección "Y")

$$\Sigma K_{y_1} = 1382.13 + 22.80 = 1404.93 \text{ T/cm}$$

2do Nivel

Muro	L (m)	e (cm)	t (cm)	h (m)	L*t(m-cm)	K (T/cm)
1	10.30	25	23	2.70	236.90	602.82
2AA'	1.45	25	23	2.70	33.35	16.47
2A"B	1.30	25	23	2.70	29.90	12.30
2CC"	2.30	25	23	2.70	52.90	51.79
2DD'	0.30	25	23	2.70	6.90	0.18
(**) 3	9.10	25	23	2.70	209.30	518.34
	24.75				569.25	1201.90

$K_{E_y 2} = 23.61$ T/cm (contribución del muro E a la rigidez en la dirección "Y")

$$\Sigma K_{y_2} = 1201.90 + 23.61 = 1225.51 \text{ T/cm}$$

3er Nivel

Muro	L (m)	e (cm)	t (cm)	h (m)	L*t(m-cm)	K (T/cm)
1	7.15	25	23	2.70	164.45	383.83
2	1.00	20	18	2.70	18.00	4.66
	8.15				182.45	388.49

$K_{E_y 3} = 23.61$ T/cm (contribución del muro E a la rigidez en la dirección "Y")

$$\Sigma K_{y_3} = 388.49 + 23.61 = 412.10 \text{ T/cm}$$

Finalmente:

1er Nivel	$\Sigma K_{x_1} =$	179.16 T/cm	$\Sigma K_{y_1} =$	1404.93 T/cm
2do Nivel	$\Sigma K_{x_2} =$	158.13 T/cm	$\Sigma K_{y_2} =$	1225.51 T/cm
3er Nivel	$\Sigma K_{x_3} =$	109.82 T/cm	$\Sigma K_{y_3} =$	412.10 T/cm

Edificación Tipo A

$$K_{\text{muros}} = \frac{E \cdot t}{[4 \cdot (H/L)^3 + 3 \cdot (H/L)]} \dots\dots\dots (I)$$

$$t = e - 2\text{cm (2cm de tarrajeo)}$$

$$E_{\text{concreto}} = 210.00 \text{ T/cm}^2$$

1) Placas de Concreto Armado

1.1) Placas 1 (solo placas rectas)

(*) Su eje en planta tiene inclinación de 5° con respecto al eje X por lo que se multiplicará la rigidez (fórmula (I)) por el coseno o el seno del ángulo para obtener así la contribución en la rigidez de la dirección en análisis.

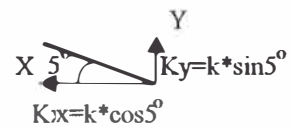

(**) Son 2 Placas, se multiplicará la fórmula (I) por 2.

Teniendo en cuenta las salvedades anteriores los resultados finales son los siguientes:

Dirección X

1er ---> 5to Nivel

	Muro	L (m)	e (cm)	t (cm)	H (m)	L*t(m-cm)	K (T/cm)
(*)	P1	11.30	20	18	2.90	203.40	4496.14
(*)	P2	7.60	20	18	2.90	136.80	2754.71
	P3	8.50	20	18	2.90	153.00	3196.93
	P4	6.80	20	18	2.90	122.40	2377.85
(**)	P7	1.95	20	18	2.90	35.10	429.10
		36.15				650.70	13254.73

6to Nivel

	Muro	L (m)	e (cm)	t (cm)	h (m)	L*t(m-cm)	K (T/cm)
(*)	P1	8.30	20	18	2.90	149.40	3089.59
(*)	P2	7.60	20	18	2.90	136.80	2754.71
	P3	5.50	20	18	2.90	99.00	1743.40
	P4	6.80	20	18	2.90	122.40	2377.85
(**)	P7	1.95	20	18	2.90	70.20	429.10
		30.15				577.80	10394.64

7mo Nivel

	Muro	L (m)	e (cm)	t (cm)	h (m)	L*t(m-cm)	K (T/cm)
(*)	P1	8.30	20	18	2.90	149.40	3089.59
(*)	P2	7.60	20	18	2.90	136.80	2754.71
	P3	5.50	20	18	2.90	99.00	1743.40
	P4	6.80	20	18	2.90	122.40	2377.85
(**)	P7	1.95	20	18	2.90	70.20	429.10
		30.15				577.80	10394.64

Dirección Y

1er ---> 5to Nivel

	Muro	L (m)	e (cm)	t (cm)	h (m)	L*t(m-cm)	K (T/cm)
(*)	P1	11.30	20	18	2.90	203.40	393.36
(*)	P2	7.60	20	18	2.90	136.80	241.01
	P5	2.60	40	38	2.90	98.80	896.96
	P6	2.60	30	28	2.90	72.80	660.92
	P7'	1.95	40	38	2.90	74.10	452.94
(**)	P7''	0.50	15	13	2.90	13.00	6.84
		26.55				598.90	2652.03

6to y 7mo Nivel

	Muro	L (m)	e (cm)	t (cm)	h (m)	L*t(m-cm)	K (T/cm)
(*)	P1	8.30	20	18	2.90	149.40	270.30
(*)	P2	7.60	20	18	2.90	136.80	241.01
	P5	2.60	40	38	2.90	98.80	896.96
	P6	2.60	30	28	2.90	72.80	660.92
	P7'	1.95	40	38	2.90	74.10	452.94
(**)	P7''	0.50	15	13	2.90	13.00	6.84
		23.55				544.90	2528.98

1.2) Placas 2 (Zona de Escalera, con placas rectas y curvas)

(**) Son 2 Placas, se multiplicará fórmula (I) por 2 .

(***) Son zonas de arco de Placas, las que se pueden aproximar a una placa inclinada con ángulo de 45° se multiplicará fórmula (I) por el coseno o el seno del ángulo para obtener así la contribución en la rigidez de la dirección en análisis.

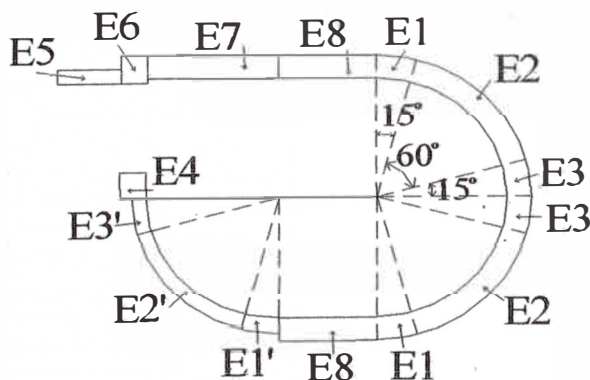

Placa P8
(Zona de Escalera)

Se considerarán las porciones de arco E2 y E'2 como placas con una inclinación de 45°

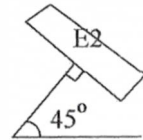
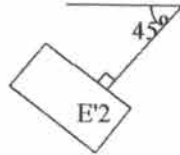

Las porciones de arco de las placas E1 y E'1 se considerarán como placas en la dirección "X"

Las porciones de arco de las placas E3 y E'3 se considerarán como placas en la dirección "Y"

La longitud de las porciones de arco de placa será la longitud de dicho arco, calculada con el ángulo y radio correspondiente

Dirección X

1er ---> 7mo Nivel

Muro	L (m)	e (cm)	t (cm)	h (m)	L*t(m-cm)	K (T/cm)
E5	0.65	15	13	2.90	8.45	7.41
E6	0.28	30	28	2.90	7.84	1.31
E4	0.27	30	28	2.90	7.56	1.18
E7	1.33	25	23	2.90	30.59	100.61
(**) E8	1.00	25	23	2.90	46.00	90.91
(**) E1	0.38	25	23	2.90	17.48	5.36
E1'	0.37	15	13	2.90	4.81	1.40
(**) y (***) E2	1.52	25	23	2.90	69.92	203.88
(***) E2'	1.49	15	13	2.90	19.37	54.64
	7.29				212.02	466.70

Dirección Y

1er ---> 7mo Nivel

Muro	L (m)	e (cm)	t (cm)	h (m)	L*t(m-cm)	K (T/cm)
E6	0.30	28	26	2.90	7.80	1.50
E4	0.30	27	25	2.90	7.50	1.44
(**) E3	0.38	25	23	2.90	17.48	5.36
E3'	0.37	15	13	2.90	4.81	1.40
(**) y (***) E2	1.52	25	23	2.90	69.92	203.88
(***) E2'	1.49	15	13	2.90	19.37	54.64
	4.36				126.88	268.23

Para todas las Placas(efectos superpuestos de Placas 1 y Placas 2 :

1er--->5to Nivel	$\Sigma K_{x_{1-5}} =$	13721.43 T/cm	$\Sigma K_{y_{1-5}} =$	2920.26 T/cm
6to Nivel	$\Sigma K_{x_6} =$	10861.35 T/cm	$\Sigma K_{y_6} =$	2797.20 T/cm
7mo Nivel	$\Sigma K_{x_7} =$	10861.35 T/cm	$\Sigma K_{y_7} =$	2797.20 T/cm

.....(α)

2) Muros de Albañilería

2.1) Muros de Albañilería en direcciones X e Y

Dirección X

1er ----> 5to Nivel

Muro	L (m)	e (cm)	t (cm)	H (m)	L*t(m-cm)	# de Muros	K (T/cm)
m1x	0.40	15	13	2.90	5.20	1	0.19
m2x	7.40	15	13	2.90	96.20	1	206.51
m3x	8.45	15	13	2.90	109.85	1	245.54
m4x	8.55	15	13	2.90	111.15	1	249.23
m5x	4.20	15	13	2.90	54.60	1	86.33
m6x	3.00	15	13	2.90	78.00	2	89.82
m7x	4.55	15	13	2.90	59.15	1	99.23
m8x	1.35	15	13	2.90	17.55	1	6.35
m9x	0.75	15	13	2.90	9.75	1	1.20
m10x	0.70	15	13	2.90	9.10	1	0.99
m11x	0.80	15	13	2.90	10.40	1	1.45
m12x	1.20	15	13	2.90	15.60	1	4.59
m13x	1.35	15	13	2.90	17.55	1	6.35
m14x	0.80	15	13	2.90	10.40	1	1.45
m15x	0.80	15	13	2.90	10.40	1	1.45
m16x	5.15	15	13	2.90	66.95	1	121.70
m17x	4.60	15	13	2.90	179.40	3	303.26
m18x	5.13	15	13	2.90	66.69	1	120.94
m19x	1.15	15	13	2.90	29.90	2	8.16
m20x	2.40	15	13	2.90	62.40	2	54.77
m21x	1.55	15	13	2.90	40.30	2	18.39
m22x	0.45	15	13	2.90	5.85	1	0.27
m23x	0.85	15	13	2.90	11.05	1	1.73
m24x	1.40	15	13	2.90	18.20	1	7.00
m25x	0.65	15	13	2.90	8.45	1	27.13
	67.63				1104.09		1664.00

6to Nivel

Muro	L (m)	e (cm)	t (cm)	H (m)	L*t(m-cm)	# de Muros	K (T/cm)
m8x	1.35	15	13	2.90	17.55	1	6.35
m13'x	0.70	15	13	2.90	9.10	1	0.99
m24x	1.40	15	13	2.90	18.20	1	7.00
m19'x	0.90	15	13	2.90	11.70	1	2.04
m20'x	1.00	15	13	2.90	13.00	2	5.51
m21x	1.55	15	13	2.90	20.15	1	9.20
m25x	0.65	15	13	2.90	8.45	1	0.79
	7.55				98.15		31.87

7mo Nivel

Muro	L (m)	e (cm)	t (cm)	H (m)	L*t(m-cm)	# de Muros	K (T/cm)
m8x	1.35	15	13	2.90	17.55	1	6.35
m13'x	0.70	15	13	2.90	9.10	1	0.99
m24x	0.80	15	13	2.90	10.40	1	1.45
m19'x	1.00	15	13	2.90	13.00	1	2.75
	3.85				50.05		11.54

Dirección Y

1er ---> 5to Nivel

Muro	L (m)	e (cm)	t (cm)	H (m)	L*t(m-cm)	# de Muros	K (T/cm)
m1y	1.95	15	13	2.90	25.35	1	16.60
m2y	2.05	15	13	2.90	26.65	1	18.79
m3y	2.40	15	13	2.90	31.20	1	27.38
m4y	0.50	15	13	2.90	6.50	1	0.37
m5y	1.10	15	13	2.90	14.30	1	3.60
m6y	1.75	15	13	2.90	22.75	1	12.62
m7y	2.35	15	13	2.90	30.55	1	26.07
m8y	2.00	15	13	2.90	26.00	1	17.68
m9y	1.90	15	13	2.90	24.70	1	15.56
m10y	1.80	15	13	2.90	23.40	1	13.57
m11y	0.70	15	13	2.90	9.10	1	0.99
m12y	1.08	15	13	2.90	14.04	1	3.42
m13y	1.35	15	13	2.90	17.55	1	6.35
m14y	0.35	15	13	2.90	4.55	1	0.13
m15y	0.80	15	13	2.90	10.40	1	1.45
m16y	1.65	15	13	2.90	21.45	1	10.84
m17y	2.00	15	13	2.90	26.00	1	17.68
m18y	1.65	15	13	2.90	21.45	2	21.67
m19y	1.05	15	13	2.90	13.65	2	6.32
m20y	1.20	15	13	2.90	15.60	2	9.18
m21y	0.35	15	13	2.90	4.60	2	0.26
m22y	0.78	15	13	2.90	10.11	1	1.34
m23y	0.45	15	13	2.90	5.85	1	0.27
m24y	0.45	15	13	2.90	5.85	1	0.27
31.66					411.61		232.40

6to Nivel

Muro	L (m)	e (cm)	t (cm)	H (m)	L*t(m-cm)	# de Muros	K (T/cm)
m8x	0.80	15	13	2.90	10.40	1	1.45
m24x	0.78	15	13	2.90	10.14	1	1.35
m20'x	1.20	15	13	2.90	15.60	1	4.59
m21x	0.35	15	13	2.90	4.55	1	0.13
m25x	0.25	15	13	2.90	3.25	1	0.05
3.38					43.94		7.57

7mo Nivel

Muro	L (m)	e (cm)	t (cm)	H (m)	L*t(m-cm)	# de Muros	K (T/cm)
m8x	0.80	15	13	2.90	10.40	1	1.45
m19'x	1.20	15	13	2.90	15.60	1	4.59
2.00					26.00		6.04

2.2) Muros de Albañilería con Inclinación en planta

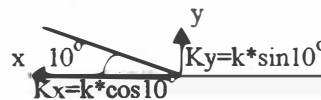
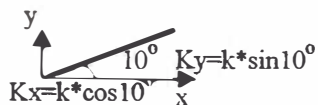

1er ---> 5to Nivel

Muro	L (m)	e (cm)	t (cm)	H (m)	L*t(m-cm)	# de Muros	Kx (T/cm)	Ky (T/cm)
M1	0.75	15	13	2.90	9.75	2	2.37	8.82
M2	1.05	15	13	2.90	13.65	1	3.11	6.14
M3	0.90	15	13	2.90	11.70	1	2.01	5.37
M4	2.30	15	13	2.90	29.90	1	24.41	7.34
	5.00				65.00		31.90	27.67

Para todos los Muros (efectos superpuestos de Muros 1.1 y Muros 2.2) :

1er--->5to Nivel	$\Sigma K_{x_{1-5}} =$	1695.91 T/cm	$\Sigma K_{y_{1-5}} =$	260.07 T/cm	
6to Nivel	$\Sigma K_{x_6} =$	31.87 T/cm	$\Sigma K_{y_6} =$	7.57 T/cm(β)
7mo Nivel	$\Sigma K_{x_7} =$	11.54 T/cm	$\Sigma K_{y_7} =$	6.04 T/cm	

2) Columnas

$K_x = \frac{12 \cdot E \cdot I_y}{H^3} \quad K_y = \frac{12 \cdot E \cdot I_x}{H^3} \quad \dots(II)$	$I = \frac{b \cdot h^3}{12} \quad \dots(III)$
---	---

b y h son dimensiones de la columna

$E_{\text{concreto}} = 210.00 \text{ T/cm}^2$	$I = \text{Mto. de Inercia (m}^4\text{)}$
$H = \text{altura de entrepiso} = 2.90\text{m.}$	

Para obtener K en (T/cm) utilizando las unidades anteriores

multiplicaremos a la fórmula (II) por 10^2 al igual para las fórmulas (4)

Caso de columnas de sección trapezoidal

a) Ejes No inclinados

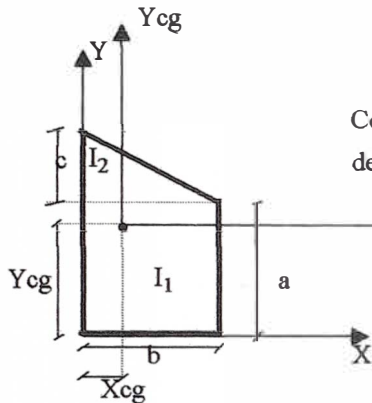

En este caso hay que adecuar la figura al sistema mostrado y las Inercias (I) calculadas con las fórmulas (1), (2) y (3) se utilizarán para calcular las rigideces usando para esto las fórmulas (4)

Coordenadas del centro de gravedad

de la figura:

$X_{cg} = \frac{b \cdot (3 \cdot a + c)}{3 \cdot (2 \cdot a + c)}$	
$Y_{cg} = \frac{(3 \cdot a^2 + 3 \cdot a \cdot c + c^2)}{3 \cdot (2 \cdot a + c)}$(1)

Inercias respecto al eje "Xcg" que pasa por el centro de gravedad de la figura \square y // al eje "X" utilizando el teorema de Steiner : $I_{cg} = I_v + A \cdot d^2$ y dividiendo a la figura en un rectángulo I_1 y un triángulo I_2 ,

$I_{1x} = \frac{b \cdot a^3}{12} + a \cdot b \cdot (Y_{cg} - a/2)^2$	
$I_{2x} = \frac{b \cdot c^3}{36} + \frac{c \cdot b}{2} \cdot (a + c/3 - Y_{cg})^2$	
$I_{x_{cg}} = I_{1x} + I_{2x}$	

Inercias respecto al eje "Ycg" que pasa por el centro de gravedad de la figura \square y // al eje "Y" utilizando el teorema de Steiner : $I_{cg} = I_v + A \cdot d^2$ y dividiendo a la figura en un rectángulo I_1 y un triángulo I_2

$I_{1y} = \frac{a \cdot b^3}{12} + a \cdot b \cdot (b/2 - X_{cg})^2$	
$I_{2y} = \frac{c \cdot b^3}{36} + \frac{c \cdot b}{2} \cdot (X_{cg} - b/3)^2$	
$I_{y_{cg}} = I_{1y} + I_{2y}$	

b) Ejes Inclinados

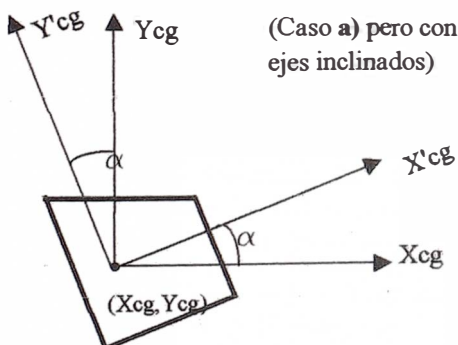

(Caso a) pero con ejes inclinados)

En el caso de ejes inclinados hallaremos la inercia

con las fórmulas (1) (2) y (3) alrededor de sus ejes X'cg e Y'cg (Ix' e Iy'); con estos valores en (4) tendremos las rigideces (K'x e K'y), utilizando estas últimas en

(5) para calcular la contribución de ambas rigideces en las direcciones X e Y

$K'x = \frac{12 \cdot E \cdot I_{y'}}{H^3}$	$K'y = \frac{12 \cdot E \cdot I_{x'}}{H^3}$	
---	---	--

$K_x = K'y \cdot \text{Sen}(\alpha) + K'x \cdot \text{Cos}(\alpha)$	
$K_y = K'x \cdot \text{Sen}(\alpha) + K'y \cdot \text{Cos}(\alpha)$	

Cálculo de columnas con sección trapezoidal .

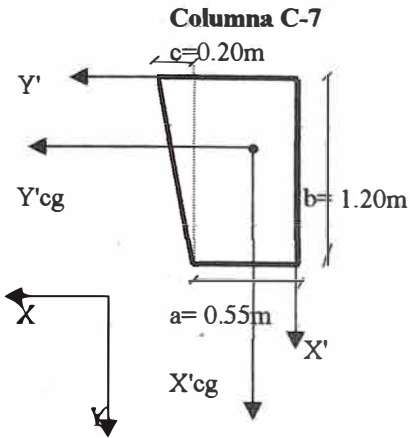

Adecuándolo al sistema del **caso a)**
entonces el eje $X=Y'cg$

el eje $Y=X'cg$

Utilizando Fórmulas (1) y (2) $\implies I_{x'cg} = I_y = 0.0288 \text{ m}^4$

Utilizando Fórmulas (1) y (3) $\implies I_{y'cg} = I_x = 0.0929 \text{ m}^4$

Luego con estas inercias y usando fórmulas (II)
tendremos la rigidez en los cuadros posteriores

Columna C-11

b) Ejes Inclinados

Adecuándolo al sistema del **caso b)**

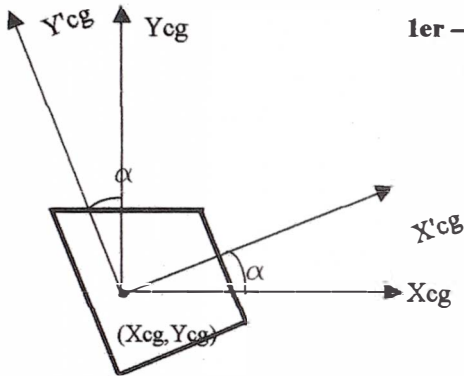

1er -> 5to Nivel

$b=0.50\text{m}$ $c=0.20\text{m}$ $a=0.90\text{m}$ $\alpha = 22^\circ$

Utilizando Fórmulas (1) y (2) $\implies I_{x'} = 0.0425 \text{ m}^4$

Utilizando Fórmulas (1) y (3) $\implies I_{y'} = 0.0104 \text{ m}^4$

Luego:

Utilizando Fórmulas (4) $\implies K'x = 107.45 \text{ T/cm}$

$K'y = 439.13 \text{ T/cm}$

Utilizando Fórmulas (5) $\implies Kx = 264.13 \text{ T/cm}$

$Ky = 447.41 \text{ T/cm}$

6to Nivel

$b=0.30\text{m}$ $c=0.15\text{m}$ $a=0.95\text{m}$ $\alpha = 22^\circ$

Utilizando Fórmulas (1) y (2) $\implies I_{x'} = 0.0272 \text{ m}^4$

Utilizando Fórmulas (1) y (3) $\implies I_{y'} = 0.0023 \text{ m}^4$

Luego:

Utilizando Fórmulas (4) $\implies K'x = 23.76 \text{ T/cm}$

$K'y = 281.04 \text{ T/cm}$

Utilizando Fórmulas (5) $\implies Kx = 127.32 \text{ T/cm}$

$Ky = 269.48 \text{ T/cm}$

Columna C-16

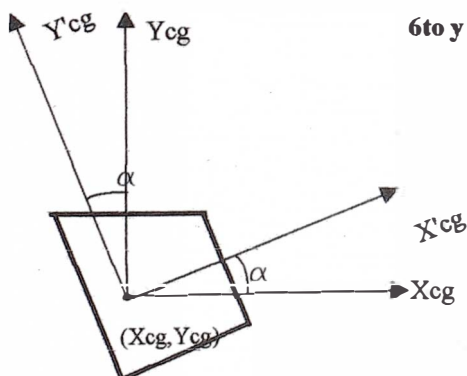

6to y 7mo Nivel

$b=0.30\text{m}$ $c=0.10\text{m}$ $a=0.80\text{m}$ $\alpha = 22^\circ$

Utilizando Fórmulas (1) y (2) $\implies I_{x'} = 0.0155 \text{ m}^4$

Utilizando Fórmulas (1) y (3) $\implies I_{y'} = 0.0019 \text{ m}^4$

Luego:

Utilizando Fórmulas (4) $\implies K'x = 19.63 \text{ T/cm}$

$K'y = 160.15 \text{ T/cm}$

Utilizando Fórmulas (5) $\implies Kx = 78.20 \text{ T/cm}$

$Ky = 155.85 \text{ T/cm}$

(*) Analizada por el caso a)

(**) Analizada por el caso b)

Dirección X

1er ----> 5to Nivel

Columna	b(m)	h (m)	Iy (m ⁴)	H (m)	# de Col	ACol(m ²)	K (T/cm)
C-1	0.40	0.60	0.0072	2.90	1	0.24	74.39
C-2	0.65	0.40	0.0035	2.90	2	0.26	71.64
C-3	0.65	0.40	0.0035	2.90	2	0.26	71.64
C-4	0.30	0.60	0.0054	2.90	2	0.18	111.59
C-5	0.70	0.50	0.0073	2.90	1	0.35	75.34
C-6	0.40	0.40	0.0021	2.90	2	0.16	44.09
(*) C-7			0.0288	2.90	1	0.78	297.58
C-8	0.45	0.58	0.0071	2.90	1	0.26	73.66
C-9	0.40	0.60	0.0072	2.90	1	0.24	74.39
C-10	0.50	0.40	0.0027	2.90	2	0.20	55.11
(**) C-11			0.0425	2.90	1	0.50	264.13
C-12	0.65	0.35	0.0023	2.90	2	0.23	47.99
C-13	0.35	0.65	0.0080	2.90	1	0.23	82.76
C-14	0.50	0.30	0.0011	2.90	1	0.15	11.62
						4.03	1355.94

6to Nivel

Columna	b(m)	h (m)	Iy (m ⁴)	H (m)	# de Col	ACol (m ²)	K (T/cm)
C-2	0.65	0.40	0.0035	2.90	2	0.26	71.64
C-3	0.65	0.40	0.0035	2.90	2	0.26	71.64
C-4	0.30	0.60	0.0054	2.90	2	0.18	111.59
C-5	0.90	0.30	0.0020	2.90	1	0.27	20.92
(**) C-11				2.90	1	0.31	127.32
C-12	0.65	0.35	0.0023	2.90	2	0.23	47.99
C-15	0.55	0.40	0.0029	2.90	2	0.22	60.62
(**) C-16				2.90	1	0.26	78.20
C-17	0.60	0.30	0.0014	2.90	1	0.18	13.95
C-18	0.70	0.30	0.0016	2.90	1	0.21	16.27
C-19	0.30	0.30	0.0007	2.90	2	0.09	13.95
						2.46	634.09

7mo Nivel

Columna	b(m)	h (m)	Iy (m ⁴)	H (m)	# de Col	ACol (m ²)	K (T/cm)
C-2	0.65	0.40	0.0035	2.90	2	0.26	71.64
C-3	0.65	0.40	0.0035	2.90	2	0.26	71.64
C-4	0.30	0.60	0.0054	2.90	2	0.18	111.59
C-12	0.65	0.35	0.0023	2.90	2	0.23	47.99
(**) C-16				2.90	1	0.26	78.20
C-17	0.90	0.30	0.0020	2.90	1	0.27	20.92
C-18	0.70	0.30	0.0016	2.90	1	0.21	16.27
C-19	0.30	0.30	0.0007	2.90	2	0.09	13.95
						1.75	432.21

Dirección Y

1er ----> 5to Nivel

Columna	b(m)	h (m)	$I_x (m^4)$	H (m)	# de Col	ACol (m^2)	K (T/cm)
C-1	0.60	0.40	0.0032	2.90	1	0.24	33.06
C-2	0.40	0.65	0.0092	2.90	2	0.26	189.17
C-3	0.40	0.65	0.0092	2.90	2	0.26	189.17
C-4	0.60	0.30	0.0014	2.90	2	0.18	27.90
C-5	0.50	0.70	0.0143	2.90	1	0.35	147.67
C-6	0.40	0.40	0.0021	2.90	2	0.16	44.09
(*) C-7			0.0929	2.90	1	0.78	959.89
C-8	0.58	0.45	0.0044	2.90	1	0.26	45.12
C-9	0.60	0.40	0.0032	2.90	1	0.24	33.06
C-10	0.40	0.50	0.0042	2.90	2	0.20	86.10
(**) C-11			0.0425	2.90	1	0.50	447.41
C-12	0.35	0.65	0.0080	2.90	2	0.23	165.52
C-13	0.65	0.35	0.0023	2.90	1	0.23	24.00
C-14	0.30	0.50	0.0031	2.90	1	0.15	32.29
						4.03	2424.46

6to Nivel

Columna	b(m)	h (m)	$I_x (m^4)$	H (m)	# de Col	ACol (m^2)	K (T/cm)
C-2	0.40	0.65	0.0092	2.90	2	0.26	189.17
C-3	0.40	0.65	0.0092	2.90	2	0.26	189.17
C-4	0.60	0.30	0.0014	2.90	2	0.18	27.90
C-5	0.30	0.90	0.0182	2.90	1	0.27	188.31
(**) C-11				2.90	1	0.31	269.48
C-12	0.35	0.65	0.0080	2.90	2	0.23	165.52
C-15	0.40	0.55	0.0055	2.90	2	0.22	114.60
(**) C-16				2.90	1	0.26	155.85
C-17	0.30	0.60	0.0054	2.90	1	0.18	55.80
C-18	0.30	0.70	0.0086	2.90	1	0.21	88.60
C-19	0.30	0.30	0.0007	2.90	2	0.09	13.95
						2.46	1458.36

7mo Nivel

Columna	b(m)	h (m)	$I_x (m^4)$	H (m)	# de Col	ACol (m^2)	K (T/cm)
C-2	0.40	0.65	0.0092	2.90	2	0.26	189.17
C-3	0.40	0.65	0.0092	2.90	2	0.26	189.17
C-4	0.60	0.30	0.0014	2.90	2	0.18	27.90
C-12	0.35	0.65	0.0080	2.90	2	0.23	165.52
(**) C-16				2.90	1	0.26	155.85
C-17	0.30	0.90	0.0182	2.90	1	0.27	188.31
C-18	0.30	0.70	0.0086	2.90	1	0.21	88.60
C-19	0.30	0.30	0.0007	2.90	2	0.09	13.95
						1.75	1018.48

Para todos las Columnas :

1er—>5to Nivel	$\Sigma Kx_{1-5} =$	1355.94 T/cm	$\Sigma Ky_{1-5} =$	2424.46 T/cm(γ)
6to Nivel	$\Sigma Kx_6 =$	634.09 T/cm	$\Sigma Ky_6 =$	1458.36 T/cm	
7mo Nivel	$\Sigma Kx_7 =$	432.21 T/cm	$\Sigma Ky_7 =$	1018.48 T/cm	

Para toda la Edificación (efectos superpuestos : $\alpha + \beta + \gamma$) :

1er—>5to Nivel	$\Sigma Kx_{1-5} =$	16773.28 T/cm	$\Sigma Ky_{1-5} =$	5604.78 T/cm
6to Nivel	$\Sigma Kx_6 =$	11527.31 T/cm	$\Sigma Ky_6 =$	4263.12 T/cm
7mo Nivel	$\Sigma Kx_7 =$	11305.09 T/cm	$\Sigma Ky_7 =$	3821.72 T/cm

Cálculo de Masas

Edificación Tipo B

Peso Unitario Albañilería=	$1800 \text{ Kg/m}^3 = 18 \frac{\text{Kg}}{\text{m}^2\text{-cm}}$
----------------------------	---

1er Nivel

Cargas

Cargas Permanentes

Debido a la parte techada con losa

PP. Aligerado (h=20cm)	300 Kg/m ²
Tabiquería	100 Kg/m ²
Acabados	100 Kg/m ²
Total ==>>> WD1=	500 Kg/m ²
A1=	62.4 m ²

Debido a la parte techada desmontable

WD1' =	80	Kg/m ²
A1' =	35.81	m ²

Carga Viva

s/c(uso vivienda)= WL1= 250 Kg/m²

Cálculo del Peso

Peso1 = PPisol + Pmuros1(1)
--------------------------	----------

$$PPisol = (WD1 + 0.8 * WL1) * A1 + WD1' * A1'$$

$$PPisol = 46544.8 \text{ Kg.} = 46.54 \text{ T}$$

PPisol = 46.54 T	...(2)
------------------	--------

$Pmuros1 = 18 \frac{\text{Kg}}{\text{m}^2\text{-cm}} * \left[\frac{H_1}{2} * (\sum L_{x1} * t_{x1} + \sum L_{y1} * t_{y1}) + \frac{H_2}{2} * (\sum L_{x2} * t_{x2} + \sum L_{y2} * t_{y2}) + H_1 * (6.22\text{m} + 3.36\text{m}) * 28\text{cm} \right]$
--

$\sum L_{x1} * t_{x1} = 1097.20 - 174.16 * 2 - 39.2 = 709.68 \text{ (m.-cm.)}$	$\sum L_{x2} * t_{x2} = 642.12 \text{ (m.-cm.)}$
$\sum L_{y1} * t_{y1} = 444.10 - 148.98 = 295.12 \text{ (m.-cm.)}$	$\sum L_{y2} * t_{y2} = 141.24 \text{ (m.-cm.)}$
$H_1 = 2.60 \text{ m.}$	$H_2 = 2.60 \text{ m.}$

==>>> Pmuros1 = 48119.76 kg

Pmuros1 = 48.12 T	...(3)
-------------------	--------

(2) y (3) en (1) :

Peso1 = 94.66 T

2do Nivel

Cargas Permanentes

Debido a la parte techada con losa

PP. Aligerado (h=20cm)	300 Kg/m ²
Tabiquería	100 Kg/m ²
Acabados	100 Kg/m ²
Total ==>>> WD2=	500 Kg/m ²
A2=	59.01 m ²

Carga Viva

s/c(uso vivienda)= WL2= 250 Kg/m²

Cálculo del Peso

$$\text{Peso2} = \text{PPiso2} + \text{Pmuros2} \quad \dots\dots\dots(1)$$

$$\text{PPiso2} = (\text{WD2} + 0.8 * \text{WL2}) * \text{A2}$$

$$\text{PPiso2} = 41307 \text{ Kg.} = 41.31 \text{ T}$$

$$\text{PPiso2} = 41.31 \text{ T} \quad \dots(2)$$

$$\text{Pmuros2} = 18 \frac{\text{Kg}}{\text{m}^2\text{-cm}} * \left[\frac{\text{H}_2}{2} * (\Sigma \text{L}_{x2} * t_{x2} + \Sigma \text{L}_{y2} * t_{y2}) + \frac{\text{H}_3}{2} * (\Sigma \text{L}_{x3} * t_{x3} + \Sigma \text{L}_{y3} * t_{y3}) \right]$$

$\Sigma \text{L}_{x2} * t_{x2} = 642.12 \text{ (m.-cm.)}$	$\Sigma \text{L}_{x3} * t_{x3} = 370.87 \text{ (m.-cm.)}$
$\Sigma \text{L}_{y2} * t_{y2} = 141.24 \text{ (m.-cm.)}$	$\Sigma \text{L}_{y3} * t_{y3} = 133.84 \text{ (m.-cm.)}$
$\text{H}_2 = 2.60 \text{ m.}$	$\text{H}_3 = 2.60 \text{ m.}$

$$\Rightarrow \text{Pmuros2} = 30140.84 \text{ kg}$$

$$\text{Pmuros2} = 30.14 \text{ T} \quad \dots(3)$$

(2) y (3) en (1) :

$$\text{Peso2} = 71.45 \text{ T}$$

3er Nivel

Cargas Permanentes

Debido a la parte techada con losa

PP. Aligerado (h=20cm) 300 Kg/m²

Total =====> WD3= 300 Kg/m²

A3= 59.01 m²

Carga Viva

s/c(uso vivienda)= WL3= 100 Kg/m² (azotea)

Cálculo del Peso

$$\text{Peso3} = \text{PPiso3} + \text{Pmuros3} \quad \dots\dots\dots(1)$$

$$\text{PPiso3} = (\text{WD3} + 0.25 * \text{WL3}) * \text{A3}$$

$$\text{PPiso3} = 19178.3 \text{ Kg.} = 19.18 \text{ T}$$

$$\text{PPiso3} = 19.18 \text{ T} \quad \dots(2)$$

$$\text{Pmuros3} = 18 \frac{\text{Kg}}{\text{m}^2\text{-cm}} * \left[\frac{\text{H}_3}{2} * (\Sigma \text{L}_{x3} * t_{x3} + \Sigma \text{L}_{y3} * t_{y3}) \right]$$

$\Sigma \text{L}_{x3} * t_{x3} = 370.87 \text{ (m.-cm.)}$
$\Sigma \text{L}_{y3} * t_{y3} = 133.84 \text{ (m.-cm.)}$
$\text{H}_3 = 2.60 \text{ m.}$

$$\Rightarrow \text{Pmuros3} = 11810.21 \text{ kg}$$

$$\text{Pmuros3} = 11.81 \text{ T} \quad \dots(3)$$

(2) y (3) en (1) :

$$\text{Peso3} = 30.99 \text{ T}$$

Edificación Tipo C

1er Nivel

Cargas Permanentes

Debido a la parte techada con losa

PP. Aligerado (h=25cm)	350 Kg/m ²
Tabiquería	100 Kg/m ²
Acabados	100 Kg/m ²
Total ==> WD1=	550 Kg/m ²
A1=	74.5 m ²

Carga Viva

s/c(uso vivienda)= WL1= 250 Kg/m²

Cálculo del Peso

$$\text{Peso1} = \text{PPiso1} + \text{Pmuros1} \quad \dots\dots\dots(1)$$

$$\text{PPiso1} = (\text{WD1} + 0.8 \cdot \text{WL1}) \cdot \text{A1}$$

$$\text{PPiso1} = 55875 \text{ Kg.} = 55.88 \text{ T}$$

$$\text{PPiso1} = 55.88 \text{ T} \quad \dots(2)$$

$$\text{Pmuros1} = 18 \frac{\text{Kg}}{\text{m}^2\text{-cm}} \cdot \left[\frac{\text{H}_1}{2} \cdot (\sum \text{L}_{x1} \cdot t_{x1} + \sum \text{L}_{y1} \cdot t_{y1}) + \frac{\text{H}_2}{2} \cdot (\sum \text{L}_{x2} \cdot t_{x2} + \sum \text{L}_{y2} \cdot t_{y2}) \right]$$

$\sum \text{L}_{x1} \cdot t_{x1} =$	122.29 (m.-cm.)	$\sum \text{L}_{x2} \cdot t_{x2} =$	108.43 (m.-cm.)
$\sum \text{L}_{y1} \cdot t_{y1} =$	616.40 (m.-cm.)	$\sum \text{L}_{y2} \cdot t_{y2} =$	569.25 (m.-cm.)
$\text{H}_1 =$	2.75 m.	$\text{H}_2 =$	2.70 m.

$$\Rightarrow \text{Pmuros1} = 34750.2 \text{ kg}$$

$$\text{Pmuros1} = 34.75 \text{ T} \quad \dots(3)$$

(2) y (3) en (1) :

$$\text{Peso1} = 90.63 \text{ T}$$

2do Nivel

Cargas Permanentes

Debido a la parte techada con losa

PP. Aligerado (h=30cm)	420 Kg/m ²
Tabiquería	100 Kg/m ²
Acabados	100 Kg/m ²
Total ==> WD2=	620 Kg/m ²
A2=	74.00 m ²

Carga Viva

s/c(uso vivienda)= WL2= 250 Kg/m²

Cálculo del Peso

$$\text{Peso2} = \text{PPiso2} + \text{Pmuros2} \quad \dots\dots\dots(1)$$

$$\text{PPiso2} = (\text{WD2} + 0.8 \cdot \text{WL2}) \cdot \text{A2}$$

$$\text{PPiso2} = 60680 \text{ Kg.} = 60.68 \text{ T}$$

$$\text{PPiso2} = 60.68 \text{ T} \quad \dots(2)$$

$$\text{Pmuros2} = 18 \frac{\text{Kg}}{\text{m}^2\text{-cm}} \cdot \left[\frac{\text{H}_2}{2} \cdot (\sum \text{L}_{x2} \cdot t_{x2} + \sum \text{L}_{y2} \cdot t_{y2}) + \frac{\text{H}_3}{2} \cdot (\sum \text{L}_{x3} \cdot t_{x3} + \sum \text{L}_{y3} \cdot t_{y3}) \right]$$

$\Sigma L_{x2} * t_{x2} =$	108.43 (m.-cm.)	$\Sigma L_{x3} * t_{x3} =$	85.75 (m.-cm.)
$\Sigma L_{y2} * t_{y2} =$	569.25 (m.-cm.)	$\Sigma L_{y3} * t_{y3} =$	182.45 (m.-cm.)
$H_2 =$	2.70 m.	$H_3 =$	2.70 m.

$\Rightarrow P_{muros2} = 22984.88 \text{ kg}$

$P_{muros2} = 22.98 \text{ T} \dots(3)$

(2) y (3) en (1) :

$Peso2 = 83.66 \text{ T}$

3er Nivel

Cargas Permanentes

Debido a la parte t echada con losa

PP. Aligerado ($h=25\text{cm}$) 350 Kg/m^2

Total $\Rightarrow W_{D3} = 350 \text{ Kg/m}^2$

$A_3 = 21.34 \text{ m}^2$

Carga Viva

s/c (uso vivienda) $\Rightarrow W_{L3} = 100 \text{ Kg/m}^2$ (azotea)

Cálculo del Peso

$Peso3 = P_{Piso3} + P_{muros3} \dots\dots\dots(1)$

$P_{Piso3} = (W_{D3} + 0.2 * W_{L3}) * A_3$

$P_{Piso3} = 8002.5 \text{ Kg} = 8.00 \text{ T}$

$P_{Piso3} = 8.00 \text{ T} \dots(2)$

$P_{muros3} = 18 \frac{\text{Kg}}{\text{m}^2\text{-cm}} * [H_3 * (\Sigma L_{x3} * t_{x3} + \Sigma L_{y3} * t_{y3})]$

$\Sigma L_{x3} * t_{x3} = 85.75 \text{ (m.-cm.)}$

$\Sigma L_{y3} * t_{y3} = 182.45 \text{ (m.-cm.)}$

$H_3 = 2.70 \text{ m.}$

$\Rightarrow P_{muros3} = 6517.26 \text{ kg}$

$P_{muros3} = 6.52 \text{ T} \dots(3)$

(2) y (3) en (1) :

$Peso3 = 14.52 \text{ T}$

Edificación Tipo A

Cargas Permanentes

Debido a la parte techada con losa

PP. Aligerado (h=20cm)	300 Kg/m ²
Vigas	100 Kg/m ³
Columnas	65 Kg/m ⁴
Tabiquería	100 Kg/m ²
Acabados	100 Kg/m ²
Total =====> WD=	665 Kg/m ² =

$$W_D = 0.665 \text{ T/m}^2$$

Carga Viva

s/c(uso Depart.)= WL= 250 Kg/m² =

$$W_L = 0.25 \text{ T/m}^2$$

$$\text{Piso Típico}_5 = \text{Piso Típico}_{1-4}$$

Piso Típico

$$\text{Piso Típico}_{1-4} = (WD + 0.8 * WL) * A_{1-5} \dots (1)$$

$$\text{Piso Típico}_6 = (WD + 0.8 * WL) * A_6 \dots (2)$$

$$\text{Piso Típico}_7 = (WD + 0.25 * WL) * A_7 \dots (3)$$

$$A_{1-5} = 400.43 \text{ m}^2$$

$$A_6 = 373.00 \text{ m}^2$$

$$A_7 = 310.42 \text{ m}^2$$

Teniendo en cuenta estos datos reemplazamos en (1) (2) y (3)

$$\text{Piso Típico}_{1-4} = 346.372 \text{ T}$$

$$\text{Piso Típico}_5 = 346.372 \text{ T}$$

$$\text{Piso Típico}_6 = 322.645 \text{ T}$$

$$\text{Piso Típico}_7 = 268.513 \text{ T}$$

.....(α)

Peso de la Placas de C.A.

Peso específico C.A. = 2.4 T/m³

H (Altura de entrepiso) = 2.9 m

$$\Sigma L * t_{1-5} = 11.44 \text{ m}^2$$

$$\Sigma L * t_6 = 10.71 \text{ m}^2$$

$$\Sigma L * t_7 = 10.71 \text{ m}^2$$

$$P_{\text{placas}_{1-4}} = \frac{2.4 * 2.9 * (\Sigma L * t_{1-5})}{2} \dots (4)$$

$$\Sigma L_{\text{placas}_7} * t_{\text{placas}_7} = 3.92 \text{ m}^2$$

$$P_{\text{placas}_5} = \frac{2.4 * 2.9 * (\Sigma L * t_{1-5} + \Sigma L * t_6)}{2} \dots (5)$$

$$P_{\text{placas}_6} = \frac{2.4 * 2.9 * (\Sigma L * t_6 + \Sigma L * t_7)}{2} \dots (6)$$

$$P_{\text{placas}_7} = \frac{2.4 * 2.9 * (\Sigma L * t_7 + \Sigma L_{\text{placas}_7} * t_{\text{placas}_7})}{2} \dots (7)$$

Teniendo en cuenta estos datos reemplazamos en (4) (5) (6) y (7)

$$P_{\text{placas}_{1-4}} = 79.60 \text{ T}$$

$$P_{\text{placas}_5} = 77.07 \text{ T}$$

$$P_{\text{placas}_6} = 74.53 \text{ T}$$

$$P_{\text{placas}_7} = 50.89 \text{ T}$$

.....(β)

Peso de Muros de Albañilería

Peso específico Alb. = 1.80 T/m³

H (Altura de entrepiso) = 2.90 m

t (espesor de muro) = 0.15 m

$$\Sigma L * t_{1-5} = 104.29 \text{ m}$$

$$\Sigma L * t_6 = 10.93 \text{ m}$$

$$\Sigma L * t_7 = 5.85 \text{ m}$$

$$P_{muros_{1-4}} = 1.8 * 2.9 * t * (\Sigma L_{1-5}) \dots(8)$$

$$P_{muros_5} = \frac{1.8 * 2.9 * t * (\Sigma L_{1-5} + \Sigma L_6)}{2} \dots(9)$$

$$P_{muros_6} = \frac{1.8 * 2.9 * t * (\Sigma L_6 + \Sigma L_7)}{2} \dots(10)$$

$$P_{muros_7} = \frac{1.8 * 2.9 * t * (\Sigma L_7)}{2} \dots(11)$$

Teniendo en cuenta estos datos reemplazamos en (8) (9) (10) y (11)

$P_{placas_{1-4}} =$	81.66 T(γ)
$P_{placas_5} =$	45.11 T	
$P_{placas_6} =$	6.57 T	
$P_{placas_7} =$	2.29 T	

Para toda la Edificación (efectos superpuestos : (α) + (β) + (γ)) :

1er—>4to Nivel	$\Sigma M_{x_{1-4}} =$ 507.63 T
5to Nivel	$\Sigma M_{x_5} =$ 468.55 T
6to Nivel	$\Sigma M_{x_6} =$ 403.74 T
7mo Nivel	$\Sigma M_{x_7} =$ 321.70 T

Sistema del Tipo A

Direccion X

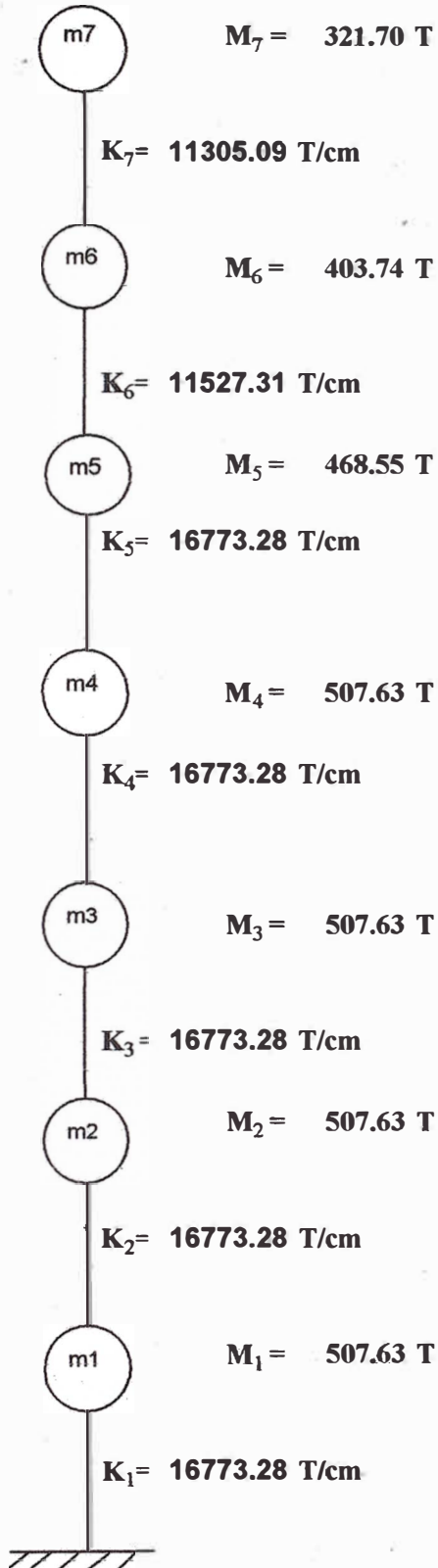

Direccion Y

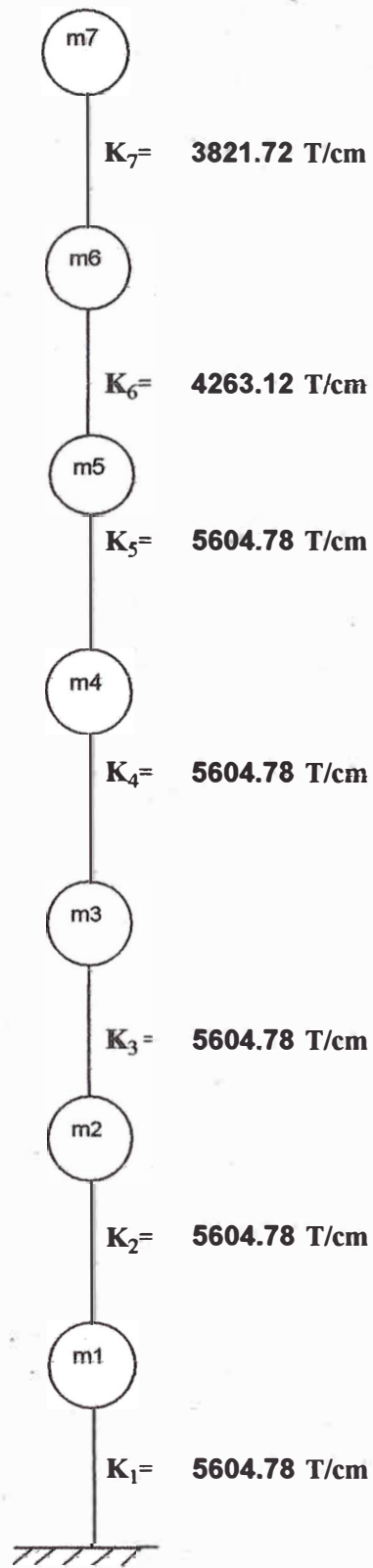

Sistema del Tipo B

Dirección X

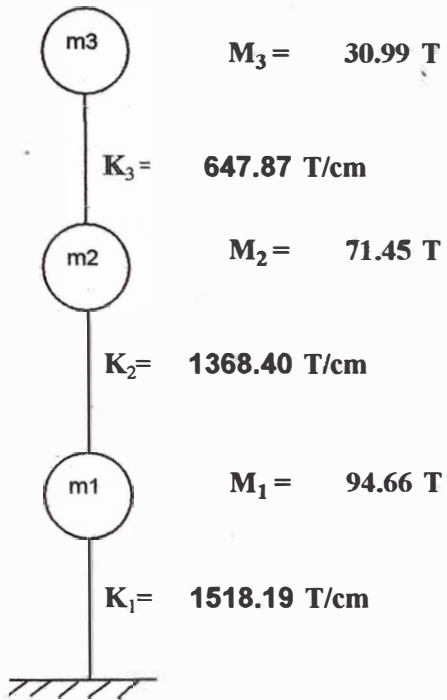

Dirección Y

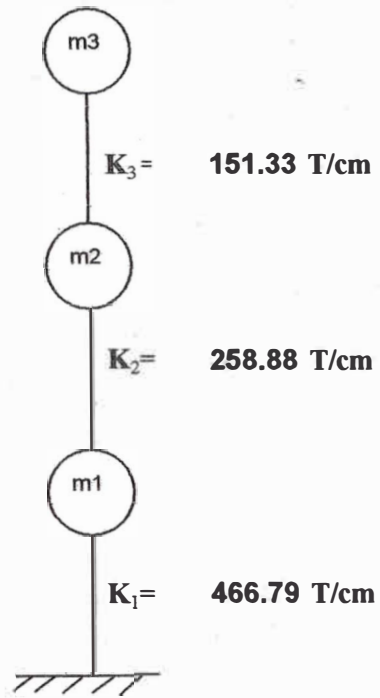

Sistema del Tipo C

Dirección X

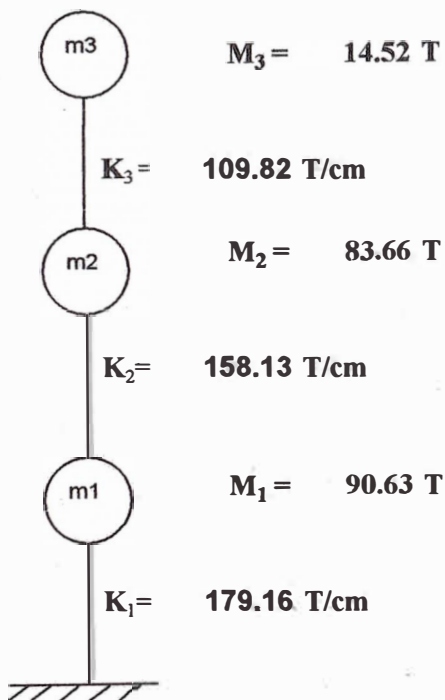

Dirección Y

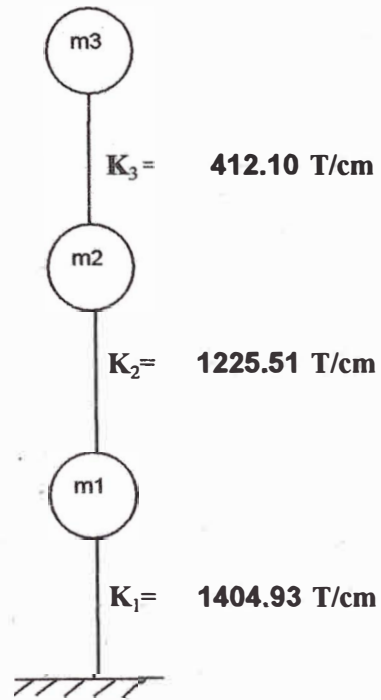

Cálculo del Q_{max} y d_{max} (Cortante y desplazamiento máximo)

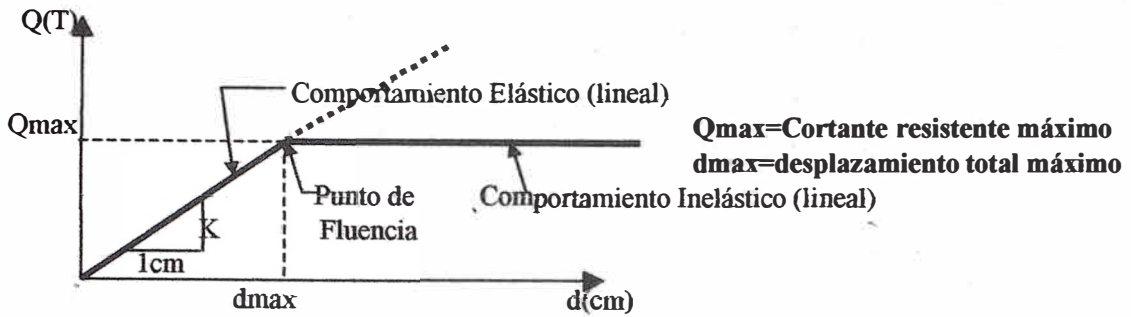

$Q_{max_n} = v_{max} * \sum A_{elem_n}$
$d_{max_n} = Q_{max_n} / K_n$

Q_{max_n} = Cortante resistente máximo del n-ésimo nivel ó piso
 d_{max_n} = desplazamiento total máximo del n-ésimo nivel ó piso

v_{max} = Esfuerzo de corte máximo según Norma de cargas
 $\sum A_{muros}$ = Sumatoria de áreas en planta de los elementos estructurales
 K_n = Rigidez del n-ésimo nivel ó piso

Albañilería

$v_{max} =$	0.0027 T/cm ²	Morteros sin cal
$v_{max} =$	0.0033 T/cm ²	Morteros con cal

Concreto Armado (f 'c = 210 Kg/cm2)

$v_{max} =$	$0.53 * (f 'c)^{1/2}$
-------------	-----------------------

Edificación Tipo B

$v_{max} =$	0.0027 T/cm ²
-------------	--------------------------

Nivel	Dirección X			Dirección Y		
	Amuros(cm ²)	$Q_{max}(T)$	$d_{max}(cm)$	Amuros(cm ²)	$Q_{max}(T)$	$d_{max}(cm)$
1er	70968.0	191.61	0.126	29512.0	79.68	0.171
2do	64212.0	173.37	0.127	14124.0	38.13	0.147
3er	37087.0	100.13	0.155	13384.0	36.14	0.239

Edificación Tipo C

$v_{max} =$	0.0027 T/cm ²
-------------	--------------------------

Nivel	Dirección X			Dirección Y		
	Amuros(cm ²)	$Q_{max}(T)$	$d_{max}(cm)$	Amuros(cm ²)	$Q_{max}(T)$	$d_{max}(cm)$
1er	12229.0	33.02	0.184	61640.0	166.43	0.118
2do	10843.0	29.28	0.185	56925.0	153.70	0.125
3er	8575.0	23.15	0.211	18245.0	49.26	0.120

Edificación Tipo A

1) Debido a las Placas de C.A.

$f'c = 210 \text{ kg/cm}^2$	
$v_{\max} = 0.53 \cdot (f'c)^{1/2} \text{ T/cm}^2$	$\Rightarrow v_{\max} = 7.680 \text{ kg/cm}^2$
	$v_{\max} = 0.0077 \text{ T/cm}^2$

Nivel	Dirección X		Dirección Y	
	Aplac.(cm ²)	Q _{max} (T)	Aplac.(cm ²)	Q _{max} (T)
1er,.....,5to	86272.00	662.61	72578.00	557.43
6to	78982.00	606.62	67178.00	515.96
7mo	78982.00	606.62	67178.00	515.96

2) Debido a las Columnas

$f'c = 210 \text{ kg/cm}^2$	
$v_{\max} = 0.53 \cdot (f'c)^{1/2} \text{ T/cm}^2$	$\Rightarrow v_{\max} = 7.680 \text{ kg/cm}^2$
	$v_{\max} = 0.0077 \text{ T/cm}^2$

Nivel	Dirección X		Dirección Y	
	Acol(cm ²)	Q _{max} (T)	Acol(cm ²)	Q _{max} (T)
1er,.....,5to	40337.50	309.81	40337.50	309.81
6to	24600.00	188.94	24600.00	188.94
7mo	17525.00	134.60	17525.00	134.60

3) Debido a los Muros de Albañilería (mortero con cal)

$v_{\max} = 0.0033 \text{ T/cm}^2$

Nivel	Dirección X		Dirección Y	
	Amuros(cm ²)	Q _{max} (T)	Amuros(cm ²)	Q _{max} (T)
1er,.....,5to	116909.00	385.80	47660.60	157.28
6to	9815.00	32.39	4394.00	14.50
7mo	5005.00	16.52	2600.00	8.58

Superponiendo efectos de 1) , 2) y 3)

Nivel	Dirección X		Dirección Y	
	Q _{max} (T)	dmax(cm)	Q _{max} (T)	dmax(cm)
1er,.....,5to	1358.22	0.081	1024.52	0.183
6to	827.94	0.072	719.39	0.169
7mo	757.73	0.067	659.14	0.172

Aplicaremos a los desplazamientos máximos el coeficiente de reducción de solicitaciones sísmicas R (Norma E.030)

Observando además si los desplazamientos relativos de entrepiso cumplen según la Norma E.030 que: $D_{relat} \leq 0.005 \cdot h_{e_n}$ (Edificaciones de Albañilería)

$D_{relat} \leq 0.007 \cdot h_{e_n}$ (Edificaciones de C.A.)

donde: h_{e_n} = Altura de entrepiso n

Tenemos:

Edificación Tipo A

$R_x = 7.5$

$R_y = 10$

$h_{e_n} =$

2.9 m

Edificación de C.A. =>

$D_{relat} \text{ max permitida} = 0.007 \cdot h_{e_n}$

$D_{relat} \text{ max permitida} = 2.03 \text{ cm}$

Nivel	Dirección X			Dirección Y		
	$R \cdot d_{max}$	Dezplzam. Relativ.		$R \cdot d_{max}$	Dezplzam. Relativ.	
	$Q_{max}(T)$	(cm)	(cm)	$Q_{max}(T)$	(cm)	(cm)
1er,.....,5to	1358.22	0.607	0.607	1024.52	1.828	1.828
6to	827.94	0.539	0.069	719.39	1.687	0.140
7mo	757.73	0.503	0.036	659.14	1.725	0.037

Cumple por Desplazamiento relativo de la Norma E. 030

Edificación Tipo B

$R_x = 6$

$R_y = 6$

$h_{e_n} =$

2.6 m

Edificación de Albañilería =>

$D_{relat} \text{ max permitida} = 0.005 \cdot h_{e_n}$

$D_{relat} \text{ max permitida} = 1.30 \text{ cm}$

Nivel	Dirección X			Dirección Y		
	$R \cdot d_{max}$	Dezplzam. Relativ.		$R \cdot d_{max}$	Dezplzam. Relativ.	
	$Q_{max}(T)$	(cm)	(cm)	$Q_{max}(T)$	(cm)	(cm)
1er	191.61	0.757	0.757	79.68	1.024	1.024
2do	173.37	0.760	0.003	38.13	0.884	0.140
3er	100.13	0.927	0.167	36.14	1.433	0.549

Cumple por Desplazamiento relativo de la Norma E. 030

Edificación Tipo C

Estructura Irregular por Esquinas entrantes

(Norma E.030)

$R_x = 4.5$

$R_y = 4.5$

$h_{e1} = 2.75 \text{ m}$

$h_{e2} \text{ y } h_{e3} = 2.70 \text{ m}$

Edificación de Albañilería => Drelat max permitida = $0.005 * h_{en}$

Drelat. Max. Permit.(1er piso) =	1.38 cm
Drelat.Max.Permitt.(2do y 3er piso) =	1.35 cm

Nivel	Dirección X			Dirección Y		
	$Q_{max(T)}$	R*dmax (cm)	Dezplzam. Relativ. (cm)	$Q_{max(T)}$	R*dmax (cm)	Dezplzam. Relativ. (cm)
1er	33.02	0.829	0.829	166.43	0.533	0.533
2do	29.28	0.833	0.004	153.70	0.564	0.031
3er	23.15	0.949	0.116	49.26	0.538	0.026

Cumple por Desplazamiento relativo de la Norma E. 030

Anexo V

- 1) Elección de un método de reparación.**
- 2) Demolición como alternativa económico-práctica.**
- 3) Demolición de muros de adobe en pésimo estado como medida de prevención.**

1) Elección de un Método de Reparación (ref. Ríos Vara,

José, "Vulnerabilidad Sísmica del Cercado de Lima", 1991.)

El problema se le presenta al ingeniero tal cual lo es al médico; es decir, comprobar la existencia de la enfermedad, diagnosticar y prescribir el remedio.

Así, el ingeniero debe conocer las diferentes formas de deterioro de las estructuras, indicar las causas de dichos desperfectos y la manera de solucionar el problema. Eso lo hará basándose en la experiencia adquirida, y elegirá una determinada técnica de reparación. Para esto es necesario una vasta información acerca de la técnica elegida, en lo referente a sus ventajas y desventajas; técnica que haya sido ya empleada para remediar deterioros similares y que no hayan dado buenos resultados.

En ocasiones será necesario experimentar algunos métodos en modelos a escala, y después elegir el que más virtudes tenga en la solución del problema.

Para elegir un método de reparación se deberá tener en cuenta las siguientes consideraciones:

- a) El trabajo debe ser efectuado a su debido tiempo sin prisa, con reflexión y cuidado.
- b) Que el gasto crece a medida que la situación se agrava.
- c) Si la obra se ha debilitado peligrosamente, la reparación debe devolverle su resistencia inicial.
- d) Que la reparación anule el progreso de los deterioros; de lo contrario darle mayor seguridad.

- e) El método elegido debe ser compatible con la causa del deterioro, es decir, que asegure que el deterioro no volverá a originarse nuevamente por los agentes que lo degradaron, ni otro posible.
- f) Usar materiales no afectos de deterioros por las causas que degradaron la estructura. Dichos materiales deberán tener perfecta adherencia con los materiales empleados en la estructura original.
- g) Que las reparaciones durante su ejecución no dificulten el servicio de la edificación.
- h) Si los daños son pocos y aislados, hacer reparaciones parciales, pero si son graves con compromiso estructural, se deberá hacer una reparación total.

La reparación de una edificación dañada no consiste únicamente en restablecer o mejorar su aspecto, sino fundamentalmente, eliminar la causa que provocó la falla y adecuarla a las exigencias de los conocimientos actuales.

2) Demolición como alternativa Económico-Práctica

(ref. Ríos Vara, José, "Vulnerabilidad Sísmica del Cercado de Lima", 1991.)

Al hacer la diagnosis acerca del deterioro de una edificación, y después de realizar las pruebas de resistencia, se presentan decisiones como la dejar la estructura en su estado actual, proceder con la reparación, o demoler la estructura para construir en su lugar otra más conveniente.

Para decidir entre reparar o demoler, se tendría que hacer un estudio económico de acuerdo a la rentabilidad de ambas decisiones. Para ello también se indican criterios empíricos, es decir reparar si su costo fuera inferior al 50% del costo de una obra nueva, de lo contrario se recomienda demoler y construir otra de substitución.

Elección del Método de Ejecución

La elección del método de ejecución más adecuado se debe hacer de acuerdo a los siguientes factores :

- a) **Seguridad** : la demolición es una operación que encierra muchos riesgos y peligros, y que requiere una experiencia y habilidad, aun cuando la estructura que se va a demoler sea relativamente pequeña.

Toda ejecución de una demolición debe asegurar la vida de los obreros y del público, así como de los vehículos, para ello, se elegirá el procedimiento y el equipo mecánico que ofrezca mayores garantías.

Se recomienda realizar una demolición a mano, siempre y cuando se asegura que al operador no le sucederá nada.

Para la seguridad del público, se deberá construir cercos, techos de protección donde sea necesario, colocar señales de advertencia, etc.

- b) **Resistencia:** de acuerdo a la resistencia, monolitismo y modos de falla, se puede elegir un proceso que garantice su rápida ejecución. La demolición a mano es recomendable para edificaciones de madera, quincha, o adobe, aun de ladrillo.

Para estructuras monolíticas, como la mampostería, concreto simple y concreto armado, y para una demolición por tramos, es necesario emplear taladros accionados por compresoras. También es recomendable la demolición por impacto.

Si la estructura está debilitada como las de quincha, madera u otros, en los que se puede aplicar ranuras para debilitarle, es factible realizar una demolición por vuelco, con ayuda de cables, tractores, palas mecánicas, etc.

c) **Economía:** Una demolición a mano tiene la ventaja de que se puede conseguir aprovechamiento de los materiales procedentes de la demolición, que se extraen con más cuidado al hacerla por partes y seleccionando el material, inclusive antes de derribarlo. Este procedimiento resulta costoso por la excesiva mano de obra, el mayor tiempo a emplearse en la ejecución y el incremento de los riesgos para los operarios, sin embargo, se abarata en cuanto a la recuperación de materiales de construcción.

La demolición mecánica requiere menos mano de obra, ofrece menos peligro en la ejecución, pero de los escombros no se recuperarán materiales de construcción; otro inconveniente, es que la demolición está limitada a la altura de operación, propia de cada máquina.

Las demoliciones por vuelco son bastante convenientes para el tipo de edificios ruinosos, porque con otros métodos, los peligros de operación serán muy grandes.

d) **Recursos:** no siendo una actividad constante, ni de gran volumen de obras en nuestro país, en la elección de un método de demolición no es primordial las condiciones de mano de obra calificada, ni de equipos apropiados al tipo de construcción que se va a demoler; generalmente se estará condicionado a mano de obra sin experiencia y propios de la región donde se efectúa la labor.

3) Demolición de muros de adobe en pésimo estado como medida de prevención (ref. Huapaya Ponce, "Estudio sísmico y

Plan de rehabilitación urbana de Cañete", Tesis UNI, 1976)

Se dan las siguientes recomendaciones:

- a) Debe demolerse todo muro de espesor menos de 30 centímetros que esté agrietado.
- b) Debe demolerse cuando la pared del muro esté humedecida y muestre deterioro (aunque éste no sea causado por el sismo).
- c) Debe demolerse cuando existe un desplome mayor de 1 centímetro por metro lineal de alto (en el caso de que la parte inferior esté humedecida, no se debe admitir desplome alguno).
- d) Debe demolerse cuando las paredes que soportan las vigas del techo, están desplomadas en el mismo sentido.
- e) Debe demolerse cuando se presenten rajaduras diagonales que atraviesen el largo del muro. Cuando estas rajaduras alcancen solamente una parte del largo del muro, puede reconstruirse la pared afectada.
- f) Debe demolerse cuando se presente un abultamiento o hinchamiento que se extiende horizontalmente a lo largo del muro.
- g) Debe demolerse cuando un muro de más de 2.50 metros de altura, no tenga techo o solera de coronación que lo sujete, debe reducirse a un máximo de 2.50 metros, aun cuando el muro se encuentre en buen estado.
- h) Debe demolerse todo el segundo piso con muros de adobe que presentan grietas, no recomendándose su reparación.
- i) Debe demolerse todos los muros bajos en los bordes de azoteas(parapetos).